

KPM III ELECTRONIC SEED MONITOR INSTALLATION INSTRUCTIONS

IS676

Rev. 9/07

Throughout these instructions the symbol  and/or the words **NOTE, IMPORTANT, CAUTION, WARNING** or **DANGER** are used to call your attention to important information. The definition of each of these terms follows:

NOTE: Indicates a special point of information or addresses a machine adjustment.

IMPORTANT: Indicates information which, if not heeded, could result in damage to the machine.



CAUTION: Indicates a potentially hazardous situation which, if not avoided, may result in minor or moderate personal injury.



WARNING: Indicates a potentially hazardous situation which, if not avoided, could result in death or serious personal injury.



DANGER: Indicates an imminently hazardous situation which, if not avoided, will result in death or serious personal injury.

Before beginning installation, read completely through these instructions.

Using the shipping order and/or the Contents Listings section at the end of these instructions, check to be sure you have all the packages needed to complete assembly.

The information used in these instructions was current at the time of printing. However, due to KINZE's continual attempts to improve its product, production changes may cause your planter to appear slightly different in detail. KINZE Manufacturing, Inc. reserves the right to change specifications or design without notice and without incurring obligation to install the same on machines previously manufactured.

Right hand (R.H.) and left hand (L.H.), as used throughout these instructions, are determined by facing in the direction the machine will travel when in use, unless otherwise stated.



DANGER: Always install all safety lockup devices or lower planter to the ground before working under or around the unit.

Monitor Serial No. _____
Measured Pulses Per Mile/km (Radar Distance Sensor) _____
Measured Pulses Per Mile/km (Magnetic Distance Sensor) _____

The KPM III Electronic Seed Monitor Package consists of (a) a KPM III console, which is mounted on the tractor; (b) seed tubes with sensors, one of which is installed in each planter row unit; (c) a magnetic distance sensor, which is installed on the planter, or a radar distance sensor, which is installed on the tractor; (d) a shaft rotation sensor kit (Models 3140, 3200, 3600, 3600TR, 3650, 3700, 3700 SDS, 3800, 3800 SDS only), which is installed on the planter drill shafts; and (e) planter harnesses (junction Y-harness and/or extension harness where applicable), to which the individual seed tube sensors connect. The primary harness, which connects the monitor console to the planter harness, is hard wired into the safety/warning light harness or control console harness included as standard equipment with the planter.

The monitor is powered by the tractor battery (requires 12 volts DC).

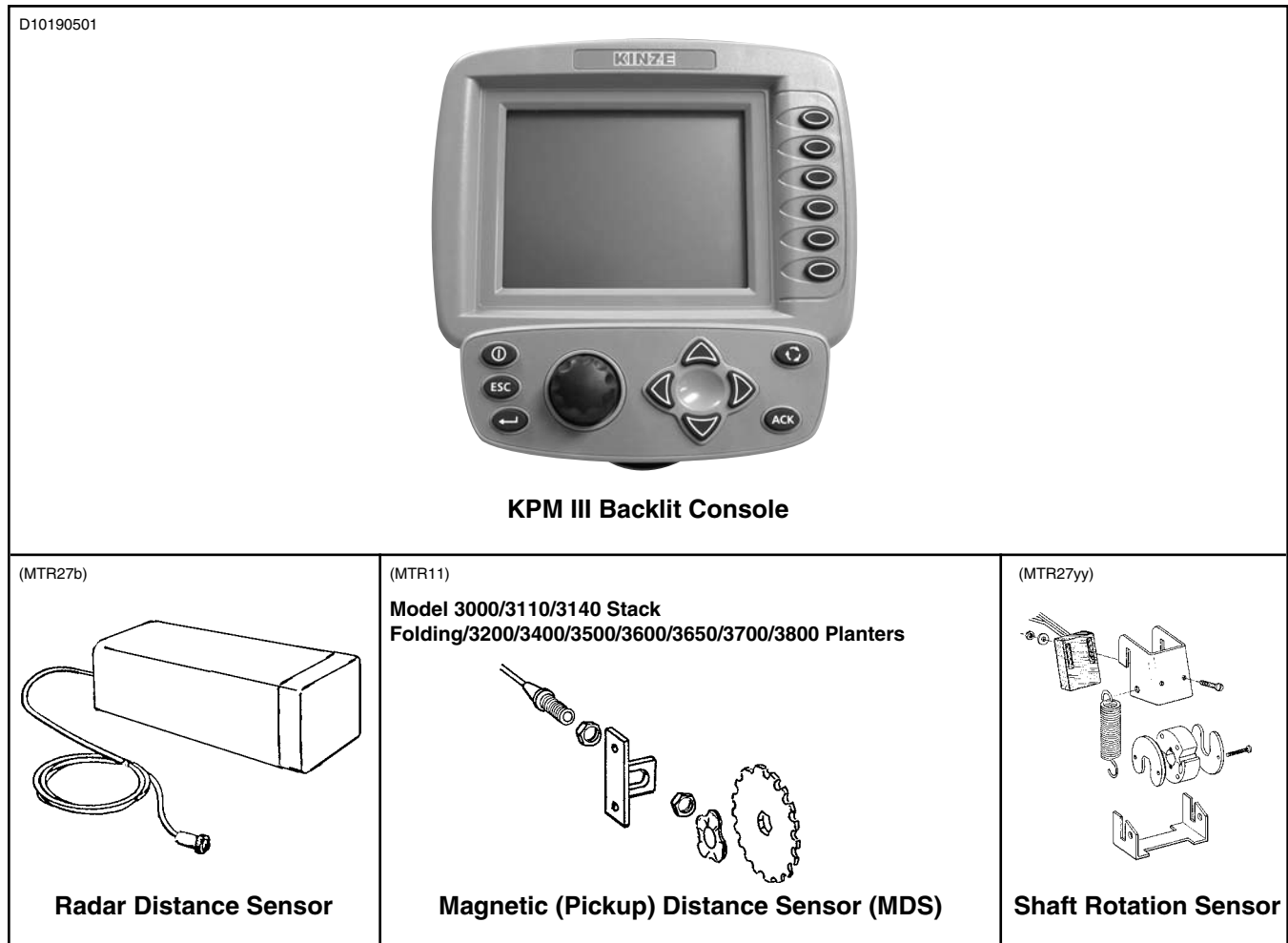

NOTE: If the console is not installed in the tractor at the time of planter installation, the console must be connected to a 12 volt power source before any of the planter components can be programmed when plugged into the planter harness. See “Connecting Seed Tubes, Shaft Rotation Sensors, Seed Tubes And/Or Radar/Magnetic Distance Sensors”.

TRACTOR COMPONENTS INSTALLATION

STEP 1. Install Console	4
STEP 2. Connect Power.....	5
STEP 3. Install Radar Distance Sensor (Applicable Only To KPM III With Radar Distance Sensor)	6

PLANTER COMPONENTS INSTALLATION

STEP 1. Install Seed Tubes Into Row Units	8
STEP 2. Install Drill Shaft Rotation Sensors (Applicable only to Model 3140 Stack Folding, Model 3200, Model 3600, Model 3600TR Model 3650, Model 3700 and Model 3800 Planters equipped with KPM III Monitor)	10
STEP 3. Install Magnetic Distance Sensor (Applicable Only To KPM III With Magnetic Distance Sensor).....	12
STEP 4. Install Harnesses Between Console And Seed Tubes.....	13
Model 3000.....	14
Model 3110.....	15
Model 3140.....	16
Model 3200.....	18
Model 3400.....	20
Model 3500.....	21
Model 3600.....	22
Model 3600TR.....	24
Model 3650.....	26
Model 3700.....	28
Model 3800.....	30

OPERATION

Introduction	32
Monitor Key Functions	33
Configuring Planter Monitor	34
Programming/Connecting Seed Tubes, Shaft Rotation Sensors And/Or Radar/Magnetic Distance Sensors...	36
Changing Volume, Contrast And Backlighting.....	38
Programming Interplant® Condition, Row Spacing And Units (Metric Or English).....	39
Programming Row Unit Alarms Levels.....	40
Speed Sensor Calibration/Programming.....	41
Reprogramming Speed Sensor.....	42
Adding Interplant® Rows (If Rear Rows Have Previously Been Programmed)	46
Adding Even-Row Package (If Front Rows Have Previously Been Programmed)	48
Enabling/Disabling Interplant® Rows.....	50
Warnings And Alarms	53
Replacing Faulty Sensor(s).....	61
Field Operation.....	55
Area Management	56
Area Counters.....	58
Clearing Field Area	59
Acre Count Mode	59

CONTENTS LISTINGS	62
--------------------------------	-----------

STEP 1 Install console.

Install the console on the tractor where it can be easily viewed and operated but not obstruct the operator's view. If required, optional adjustable arms are available from aftermarket suppliers.

Using the mounting ball as a template, mark the location of the three or four bracket mounting holes. Drill $\frac{7}{32}$ " diameter holes.

(MTR48/MTR49)

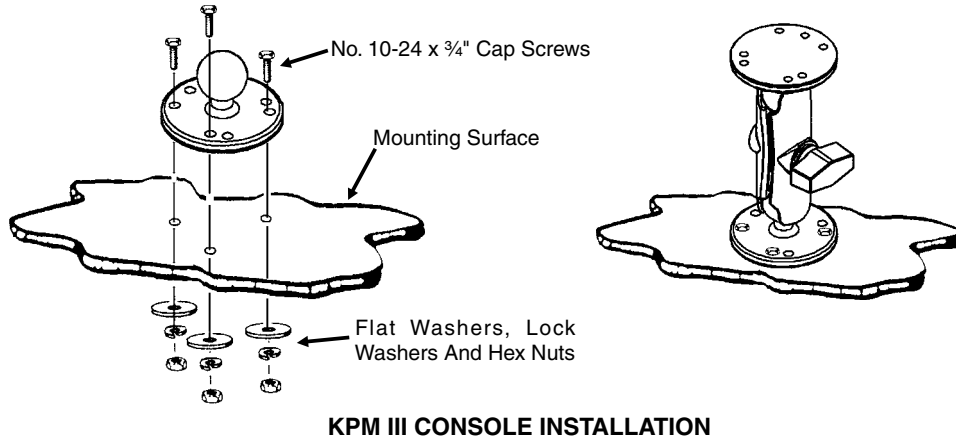

CAUTION: Make sure the opposite side of the drilling surface has ample clearance and is free of wiring, etc.

Attach the first mounting bracket to the mounting surface using three No. 10-24 x 3/4" cap screws, flat washers, lock washers and hex nuts provided.

Attach second mounting bracket to KPM III console.

Secure KPM III console to mounting bracket using the adjustable arm. Tighten the T-bolt to lock the console in the desired position.

D11040520/D10190501

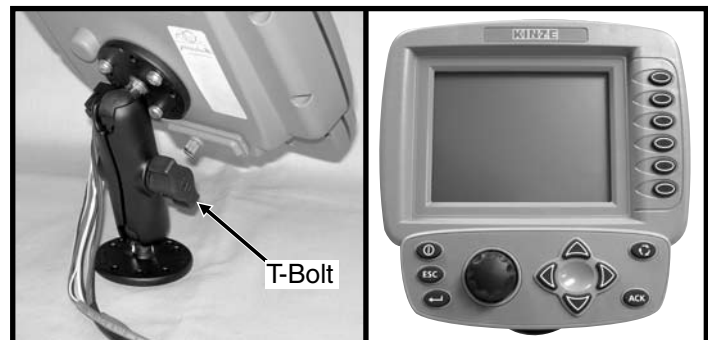

NOTE: An optional 10" monitor/radar adapter cable (GA9144) is available for use between the console and radar distance sensor to adapt the monitor system to various tractor radar systems. DO NOT CONNECT THE ADAPTER TO THE CONSOLE AT THIS TIME.

STEP 2 Connect power.

The monitor system operates on 12VDC only. The console power lead has a 3-terminal AMP CPC female connector which can be connected to the convenience outlet provided in late model tractors.

D091102102



KPM III Monitor System

03199703

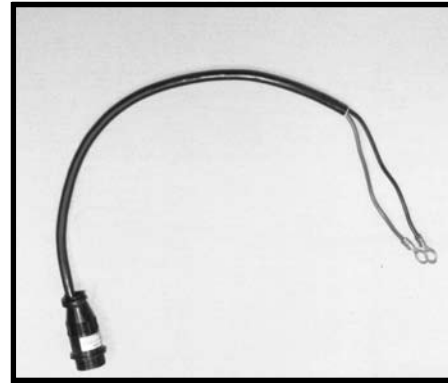

Power Lead Adapter (GA7856)

Use GA7856 power lead adapter (customer-supplied) if a two wire connection is needed. Connect the “red” wire to the positive (+) battery terminal and the “black” wire to the negative (-) battery terminal. Refer to the following illustrations for typical battery connections.

(MTR16a)

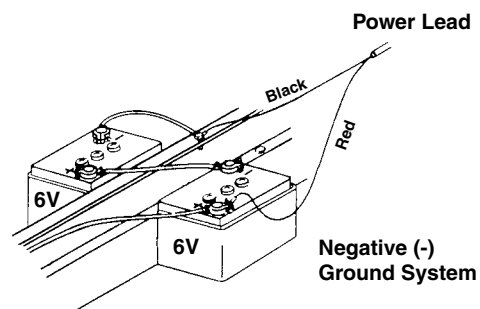
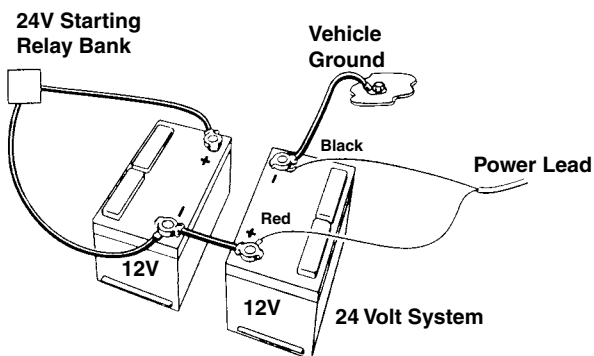
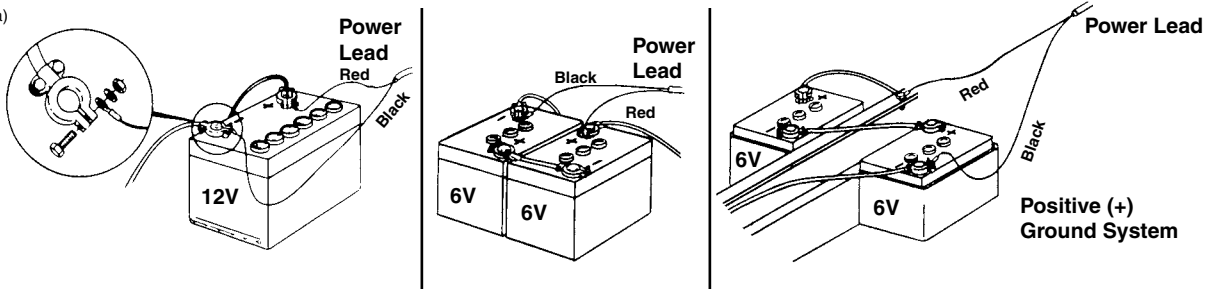

If your tractor’s battery arrangement is different than shown or if there is any question as to where to connect the power lead, use a voltmeter to make sure you measure from 11 volts to 14 volts across the “red” and “black” leads. On tractors using two 12 volt batteries, make sure console power leads are connected directly to the grounded battery.

NOTE: Good battery connections are essential for proper monitor operation. Make sure connections are clean and tight. If the console is connected to less than 10 volts or more than 15 volts, an audible alarm will sound and a message will be displayed on the screen.

NOTE: The battery, ignition and electrical system of the tractor must be in good working order.

Secure power lead with tie straps furnished with console. DO NOT route console power lead in close proximity to existing battery cables.

STEP 3 Install radar distance sensor. (Applicable Only To KPM III With Radar Distance Sensor)

- A. Install radar sensor onto mounting bracket using four 1/4"-20 x 1/2" cap screws and lock washers as shown below. Be sure cut outs in bracket are facing away from the radar sensor.

(MTR33)

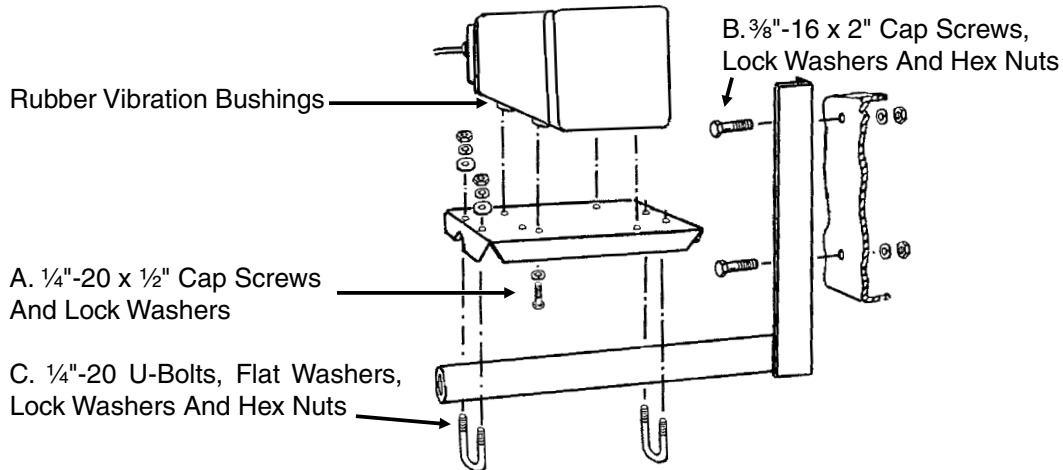

- B. Drill two holes in the mounting surface and install pipe bracket. Install pipe bracket onto tractor using two 3/8"-16 x 2" cap screws, lock washers and hex nuts. Prior to installation of the pipe bracket onto the tractor, read the following precautions and recommendations.

- Install the radar distance sensor approximately 2 feet above the ground.
- The radar distance sensor should be mounted facing rearward for more physical protection to the sensor.
- The radar distance sensor should not be mounted in close proximity to any major heat sources.
- The face of the radar distance sensor must have an unobstructed view of the ground.
- The radar distance sensor should be located where fluids do not drip directly on the unit.
- The mounting should offer a minimal amount of vibration potential. Excessive vibration may cause erroneous speed readings when the tractor is stationary.
- The radar distance sensor must be mounted so it "sits on top" of the rubber vibration bushings. It should not be mounted so it hangs from the rubber bushings.

NOTE: Welding the bracket is not recommended in case the radar distance sensor needs to be relocated due to vibration problems.

- C. Install radar sensor/mounting bracket onto pipe bracket using two 1/4"-20 U-bolts, flat washers, lock washers and hex nuts. Tighten the U-bolts just enough so the radar sensor can still be tipped by hand.

- E. With the tractor parked on a flat surface, place a level so it aligns with the arrowed line on the radar sensor. Tip the radar sensor until the bubble on the level is balanced at mid-line which will place the sensor at a 35° angle. Tighten the U-bolts to secure the radar sensor mounting bracket to the pipe bracket.

(MTR34)

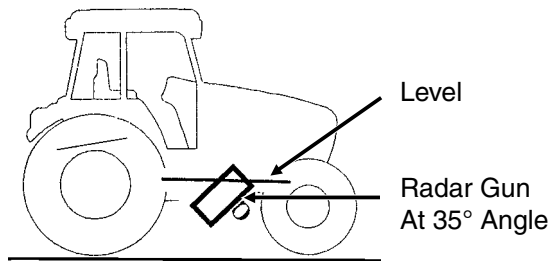

05319808

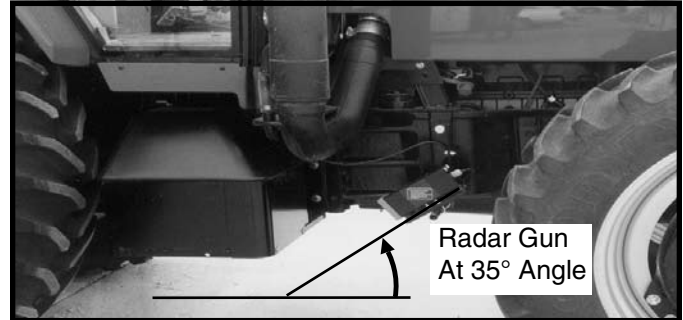

- F. Route the cable from the radar sensor to the proper location and secure with tie straps. Use care in routing cable to avoid sources of heat or areas that may pinch or damage the cable.

IMPORTANT: DO NOT CONNECT radar distance sensor to the monitor system at this time. See “Programming/Connecting Seed Tubes, Shaft Rotation Sensors And/Or Radar/Magnetic Distance Sensors”.

NOTE: If the monitor is using the tractor’s radar for ground speed input, a customer supplied Y-cable may be required to complete the installation.

NOTE: After installation of the radar distance sensor or any time the sensor is moved, the console must be calibrated. See “Speed Sensor Calibration/Programming” in this instruction or in the Operation Section of the Operator & Parts Manual supplied with the planter.

NOTE: Excessive vibration may cause ground speed (MPH or KM/H) readings to be above zero when the tractor is stationary. To check for vibration, start tractor engine and slowly increase engine RPM (while watching the ground speed readout) to approximately 1800 RPM. If the ground speed readings are above zero, the radar distance sensor must be mounted in an alternate, more stable location.

STEP 1 Install seed tubes into row units.

Insert seed tube w/sensor into planter row unit shank and route the sensor lead toward the planter toolbar. Position seed tube hook over lower cross pin as illustrated below. Replace upper clevis pin through holes on upper part of seed tube assembly. Replace hair pin clip on clevis pin. Extend sensor lead toward planter toolbar as shown on the following page. Secure sensor lead to row unit with ties provided, allowing slack in lead for movement of parallel linkage.

METR55b/D01250502/RU138a

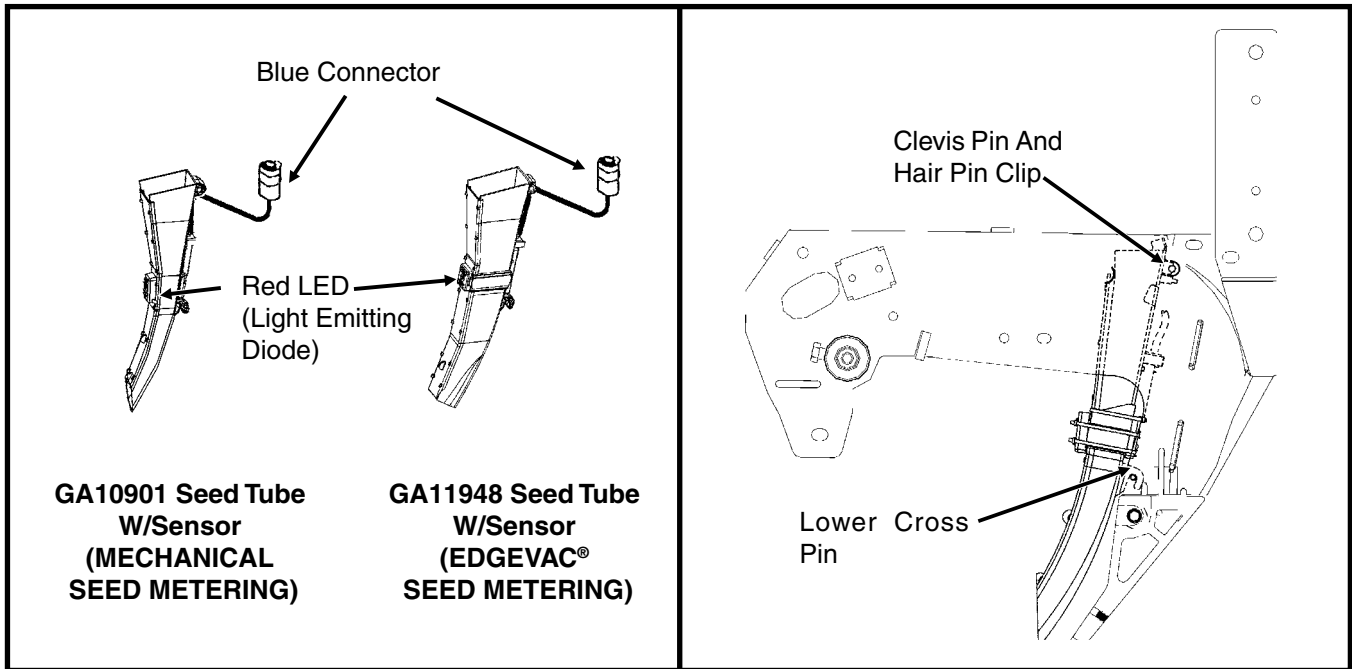

NOTE: Make sure sensor lead cannot be damaged by parallel linkage movement or come in contact with drill shaft. DO NOT CONNECT SENSOR LEAD TO PLANTER HARNESS AT THIS TIME.

D070799143a

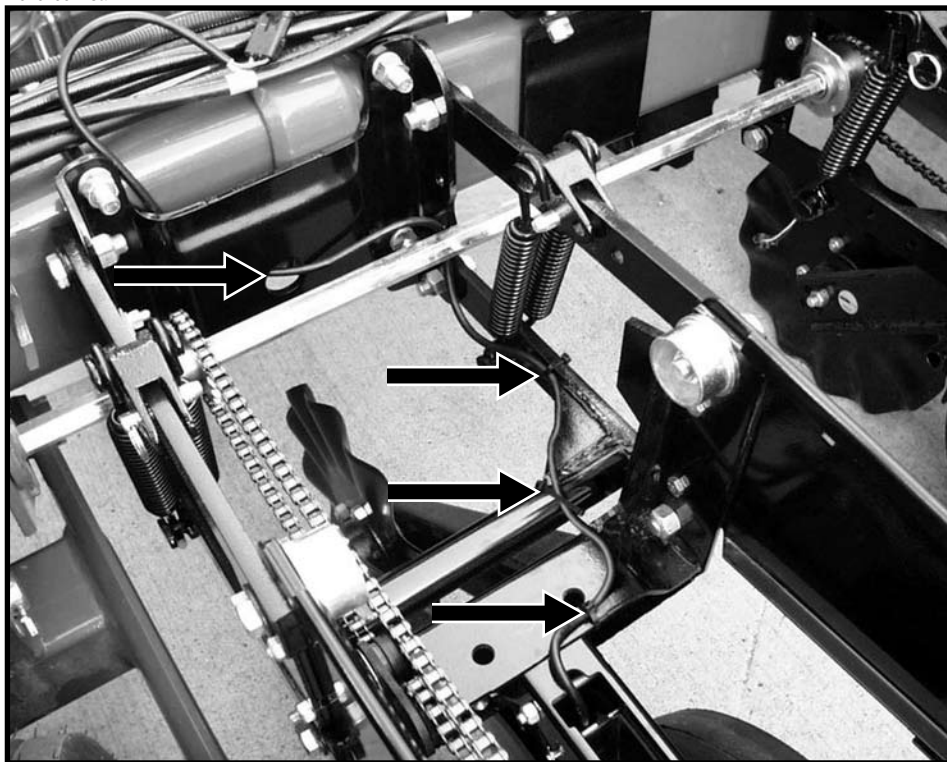

Pull Row Unit Sensor Lead Routing

D102700108

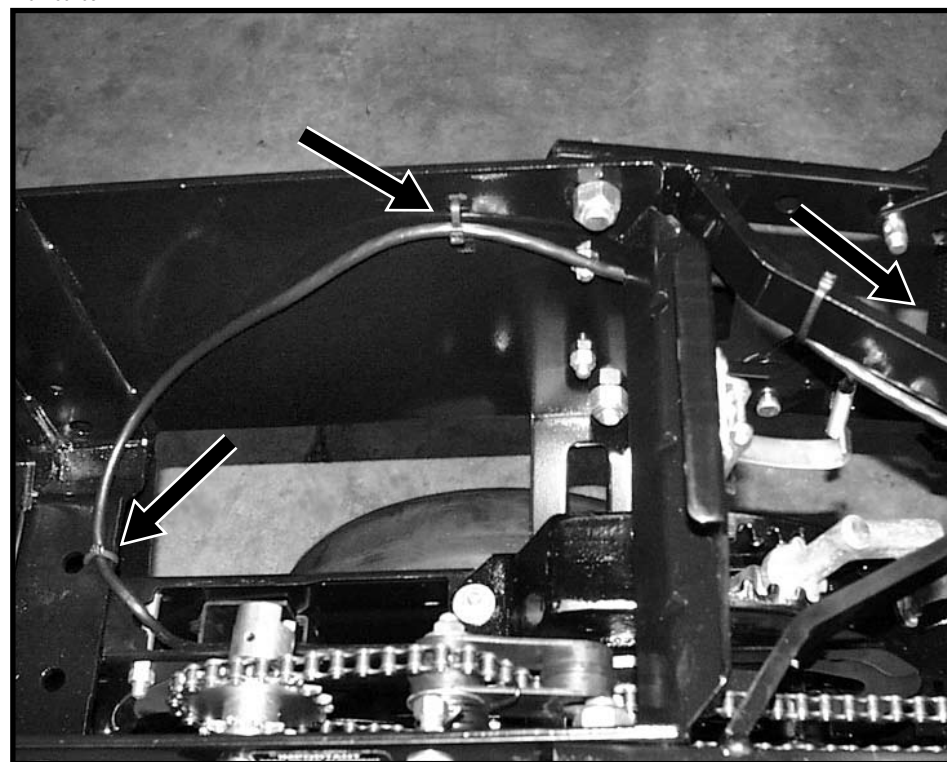

Push Row Unit Sensor Lead Routing

STEP 2 Install drill shaft rotation sensors.

(Applicable Only To Model 3140 Stack Folding, Model 3200, Model 3600, Model 3600TR, Model 3650, Model 3700 And Model 3800 Planters Equipped With KPM III Monitor)

Install the drill shaft rotation sensors onto the support plates onto the toolbar between row unit as shown in the illustrations on pages 16 through 31. In most applications the rotation sensor will be installed between the outer most row unit on each side of the planter.

(PLTR185a)

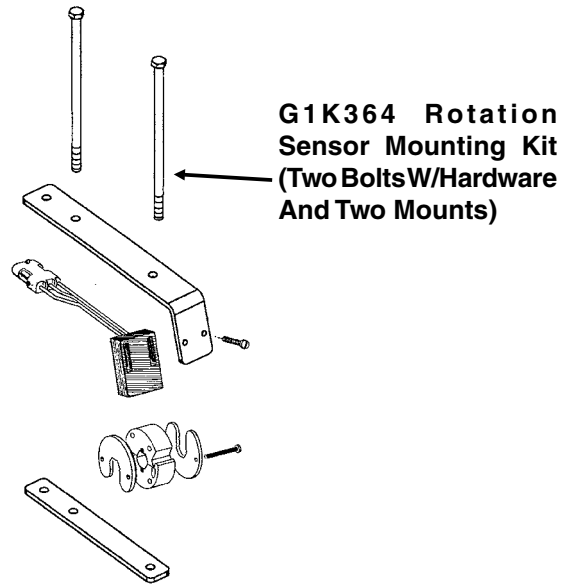

- A. Place top half of actuator over bottom half and snap the sensor actuator onto the drill shaft as shown at right.

NOTE: DO NOT SLIDE the halves together.

09109708

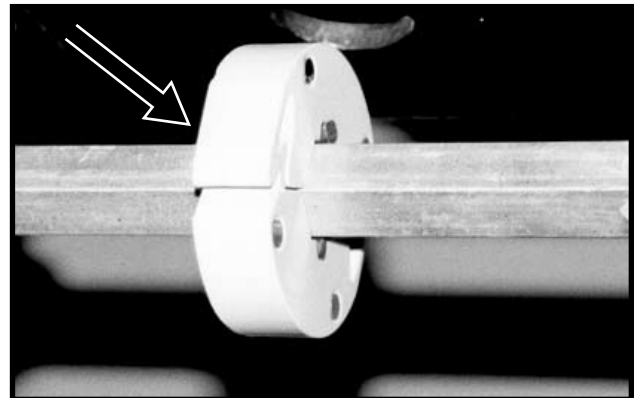

- B. Bolt plastic cover onto each side of actuator using two No. 8-32 x 1 1/4" stainless steel machine screws, lock washers and nuts. See photo at right and illustration above.

01189911

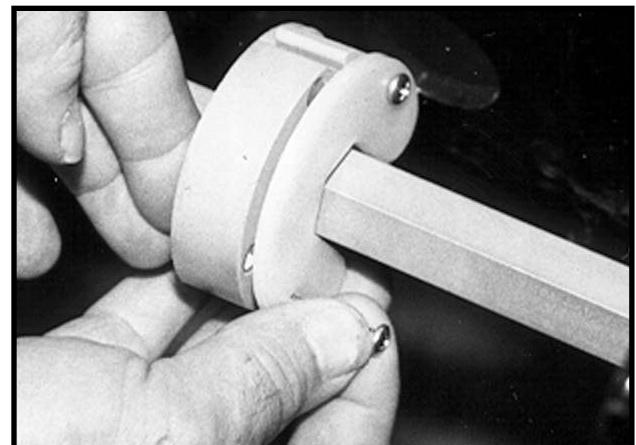

PLTR185a

- C. Install sensor onto mount using the two No. 10 pan head screws, SAE washers and nuts as shown at right. DO NOT tighten screws at this time.

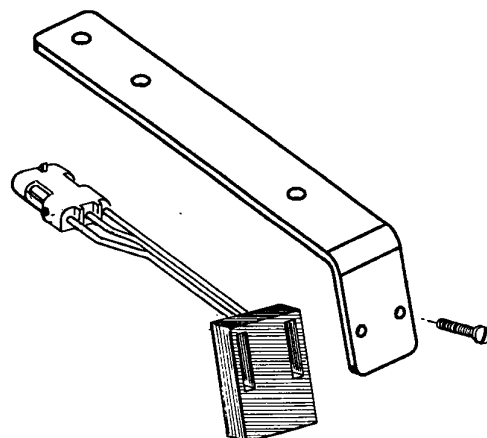

D072407103

- D. Position assembly over drill shaft as shown.
 E. Position spring mount under row unit mounting support plate and connect springs as shown above.



D072407101

- F. Center sensor over actuator with maximum 1/8" gap between sensor and actuator. Tighten sensor mounting hardware.

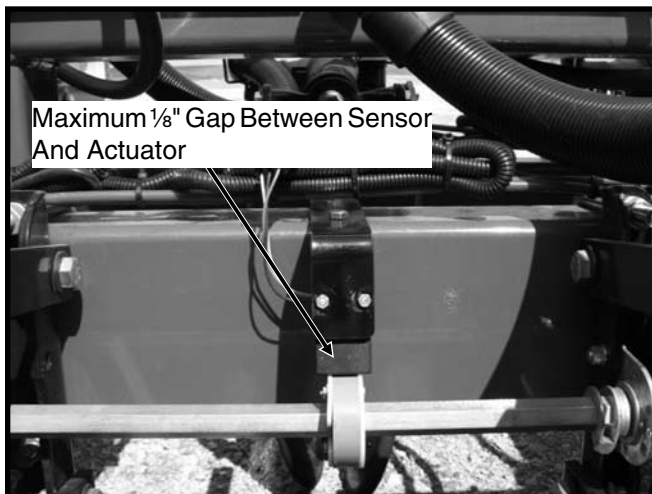

- G. Repeat Steps A through G on opposite end of planter.

IMPORTANT: DO NOT CONNECT drill shaft rotation sensor to the planter harness at this time. The drill shaft rotation sensors will be connected when the seed tubes are connected.

STEP 3 Install magnetic distance sensor. (Applicable Only To KPM III With Magnetic Distance Sensor)

See installation instruction supplied with **Magnetic Distance Sensor Package** (A6147 for Model 3000, 3110 Rigid, 3140 Stack Folding, 3200, 3400, 3500, 3600, 3650, 3700 and 3800 Planters) for installation of that package.

See illustrations on pages 14 through 31 for installation locations as applicable. Secure adapter with tie straps.

03199702

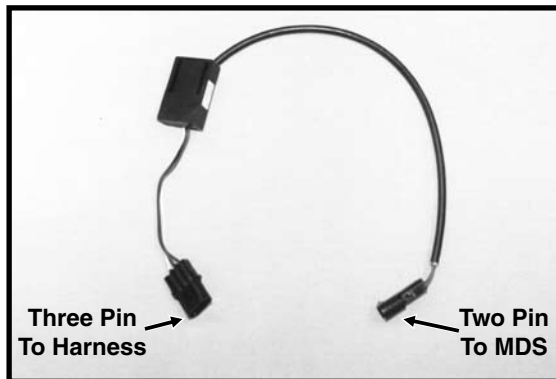

Magnetic Distance Sensor (MDS) Adapter - Connect To Magnetic Distance Sensor Lead

01189910

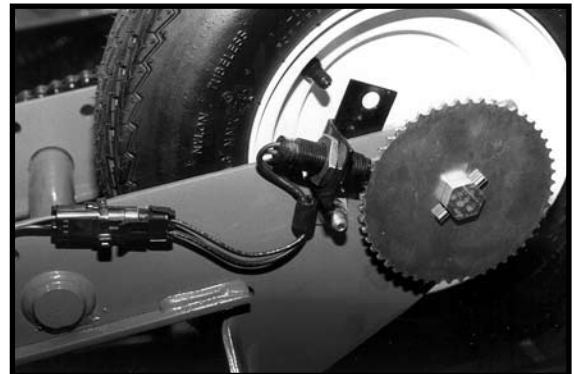

Connect MDS Adapter To MDS Lead. See Installation Instruction Supplied With MDS Package.

IMPORTANT: DO NOT CONNECT magnetic distance sensor adapter to the planter harness at this time.

STEP 4 Install harnesses between console and seed tubes.

NOTE 1: DO NOT connect seed tubes to harness during this step.

NOTE 2: When installing harnesses, take care to locate harnesses where they will not be pinched, cut or damaged by any moving parts during normal operation of the planter.

Refer to the illustrations on the following pages for additional information.

(MTR46cc/A9152/ELC10e/ELC10d/MTR52)

A. Lay planter harness(es) out on top of planter frame. Each planter harness will have more connectors than needed for the number of planter row units. For example, a 12 row harness will have 16 connectors and a 16 row harness will have 20 connectors. In addition to seed tube connections, one connector is used to connect the planter harness to the monitor console on the tractor. A second additional connector is used for MDS hookup (If Applicable) or for use with an optional extension harness to add an additional length of planter harness. Extra connectors may also be used to connect the drill shaft rotation sensors (If Applicable).

NOTE: DO NOT CONNECT harness to any sensors at this time.

B. Install extension harness where applicable. See the following pages for model specific installation instructions.

NOTE: The primary harness is included in the safety/warning light wiring harness or tractor and planter control console wiring harnesses.

C. Connect harnesses installed in Steps A and B to each other.

D. Connect console to a 12 volt power source. See STEP 2 in "Tractor Components Installation".

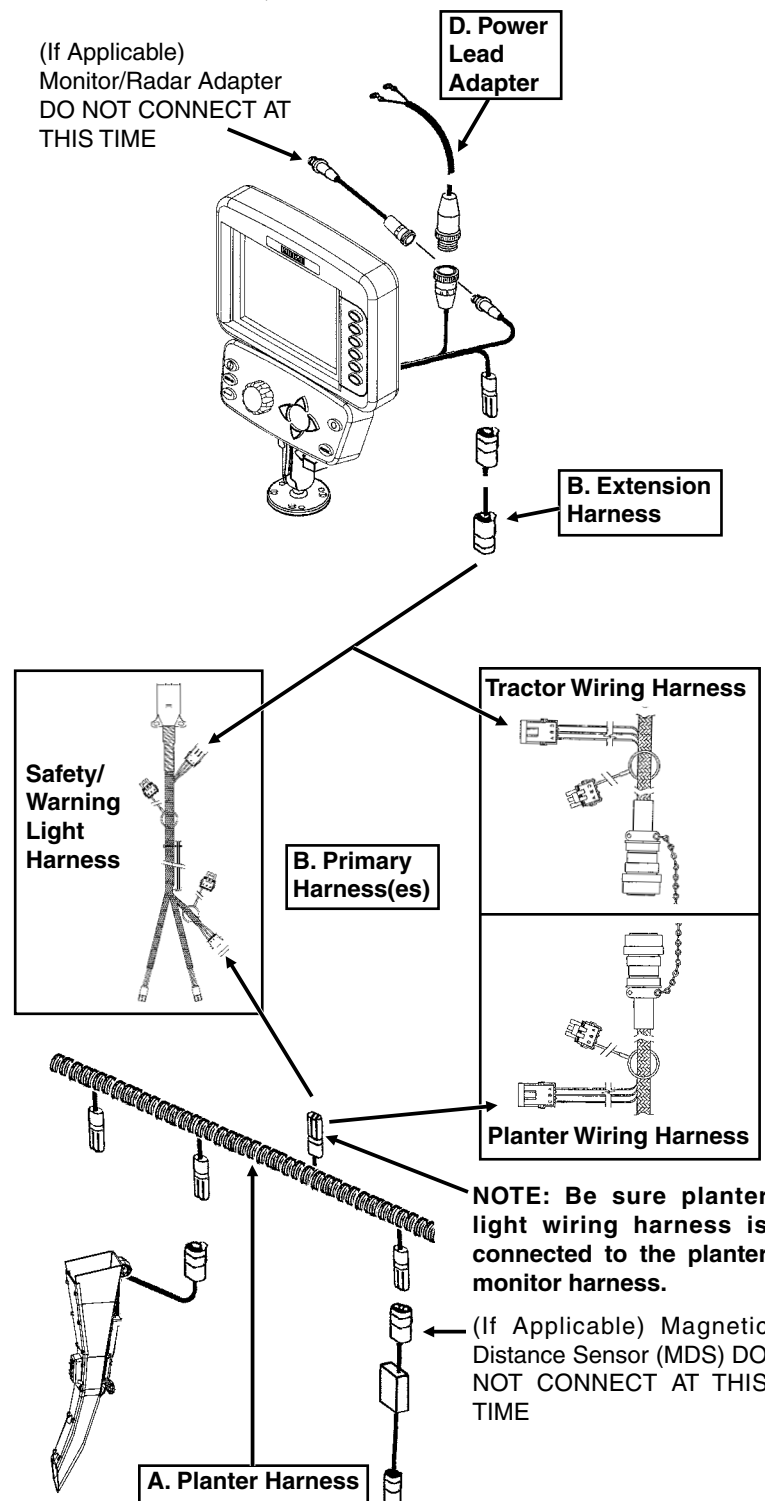

MODEL 3000 PULL TYPE PLANTER WITH INTERPLANT® PACKAGE

(8 Row With 7 Push Row Units Shown)

(PLTR116)

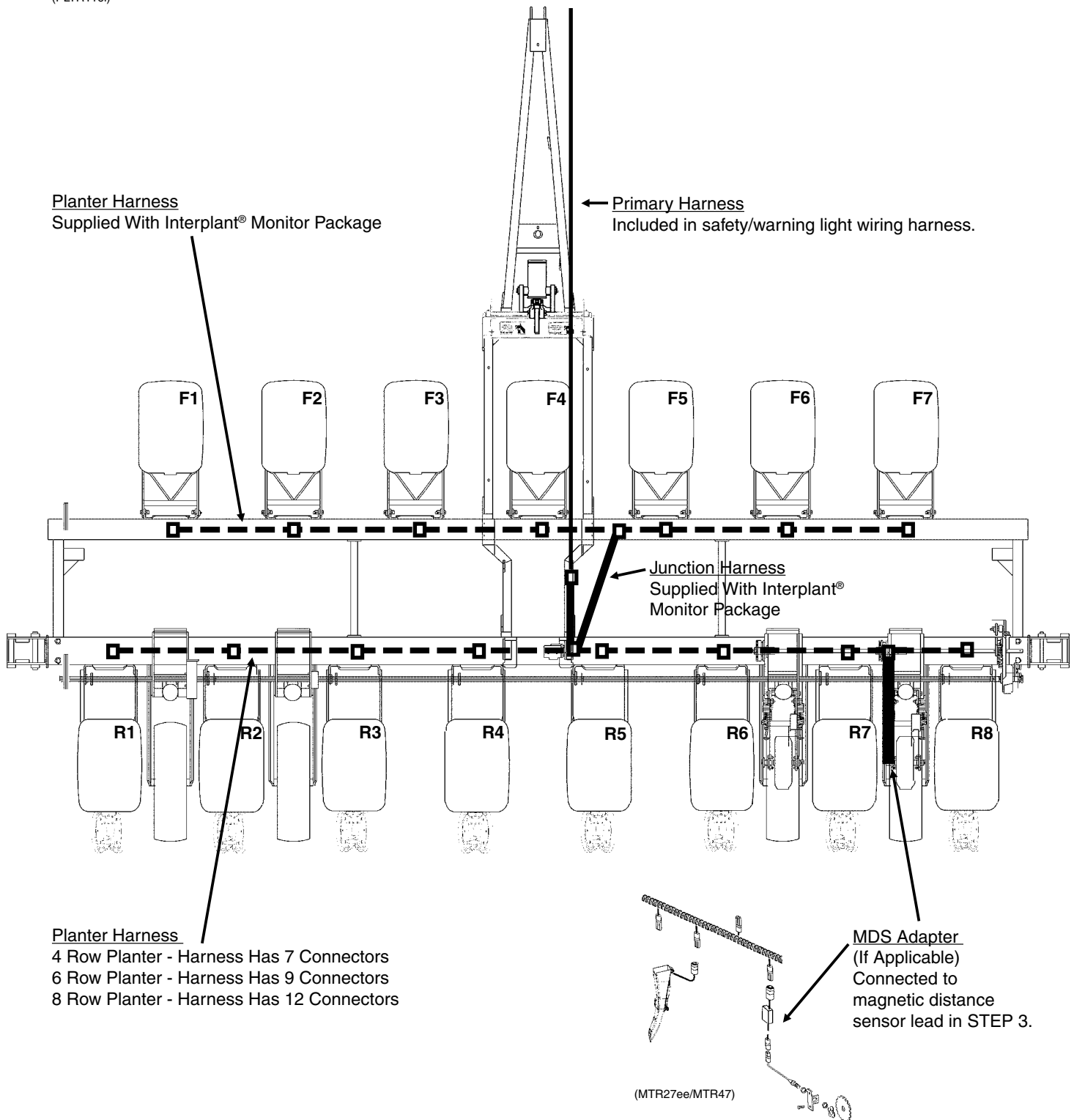

NOTE: If the radar distance sensor is being installed, it is connected to the radar sensor cable on the console and the extra connector on the planter harness is not used. If the magnetic distance sensor is being installed, it is connected to the planter harness and the sensor cable on the console is not used. Bundle and tie any unused harness connectors to the harness so they will not be damaged. **DO NOT** connect distance sensor or seed tubes at this time.

MODEL 3110 THREE POINT MOUNTED PLANTER (Rigid Frame)

(8 Row Shown)

(PLTR117h)

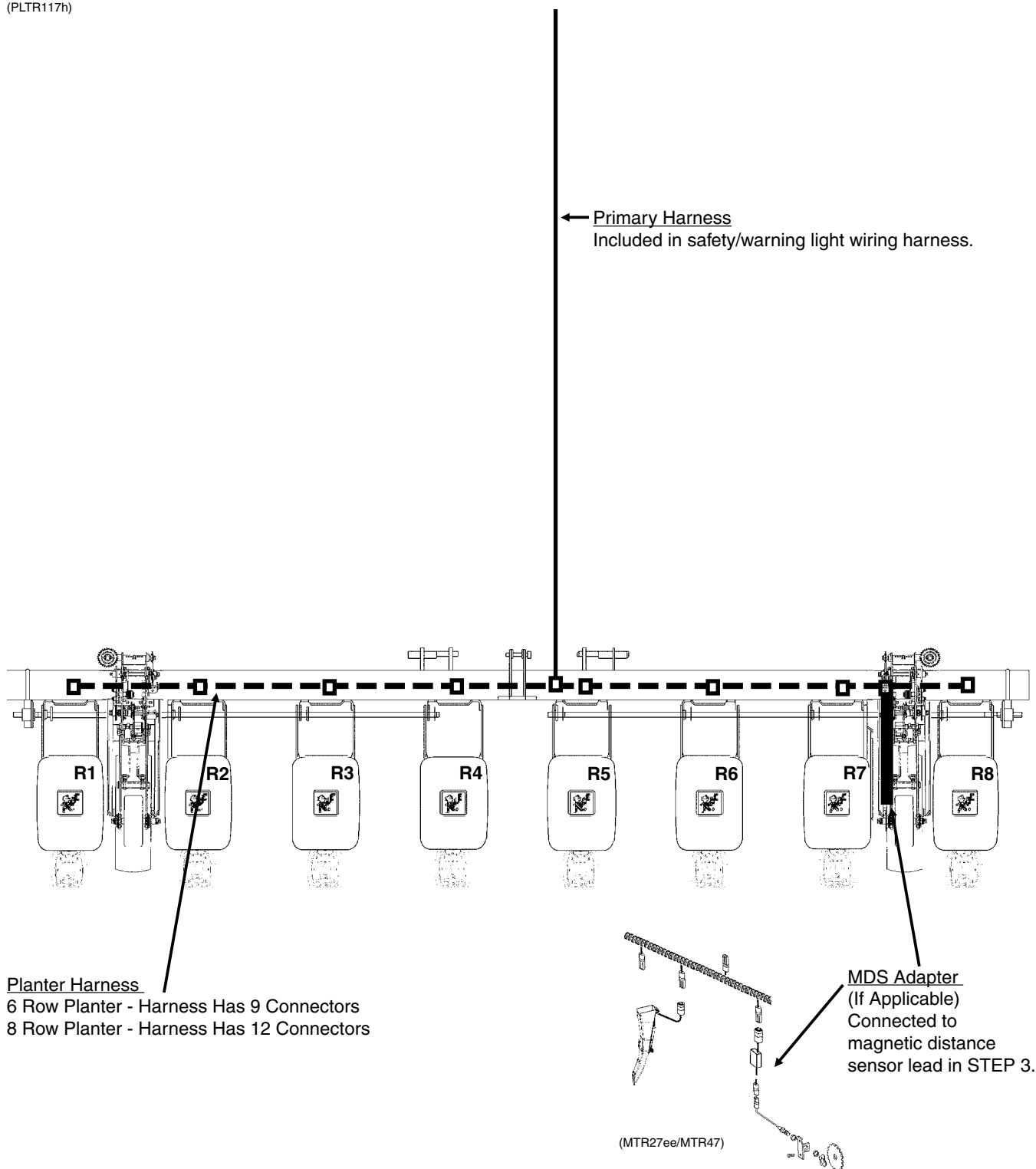

NOTE: If the radar distance sensor is being installed, it is connected to the radar sensor cable on the console and the extra connector on the planter harness is not used. If the magnetic distance sensor is being installed, it is connected to the planter harness and the sensor cable on the console is not used. Bundle and tie any unused harness connectors to the harness so they will not be damaged. **DO NOT** connect distance sensor or seed tubes at this time.

MODEL 3140 THREE POINT MOUNTED PLANTER (Stack Folding)

(8 Row Shown)

(PLTR119a)

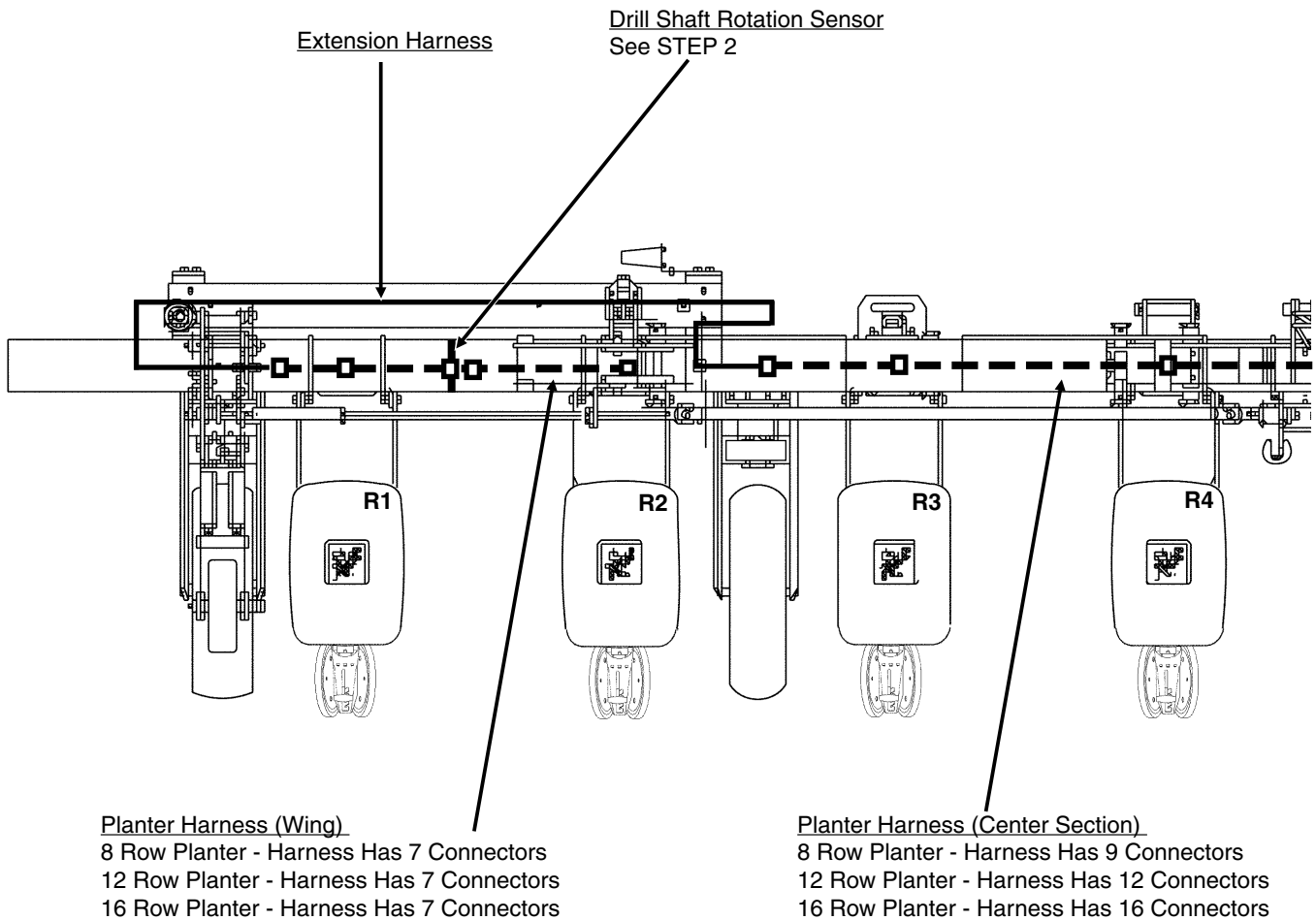

NOTE: If the radar distance sensor is being installed, it is connected to the radar sensor cable on the console and the extra connector on the planter harness is not used. If the magnetic distance sensor is being installed, it is connected to the planter harness and the sensor cable on the console is not used. Bundle and tie any unused harness connectors to the harness so they will not be damaged. **DO NOT** connect distance sensor or seed tubes at this time.

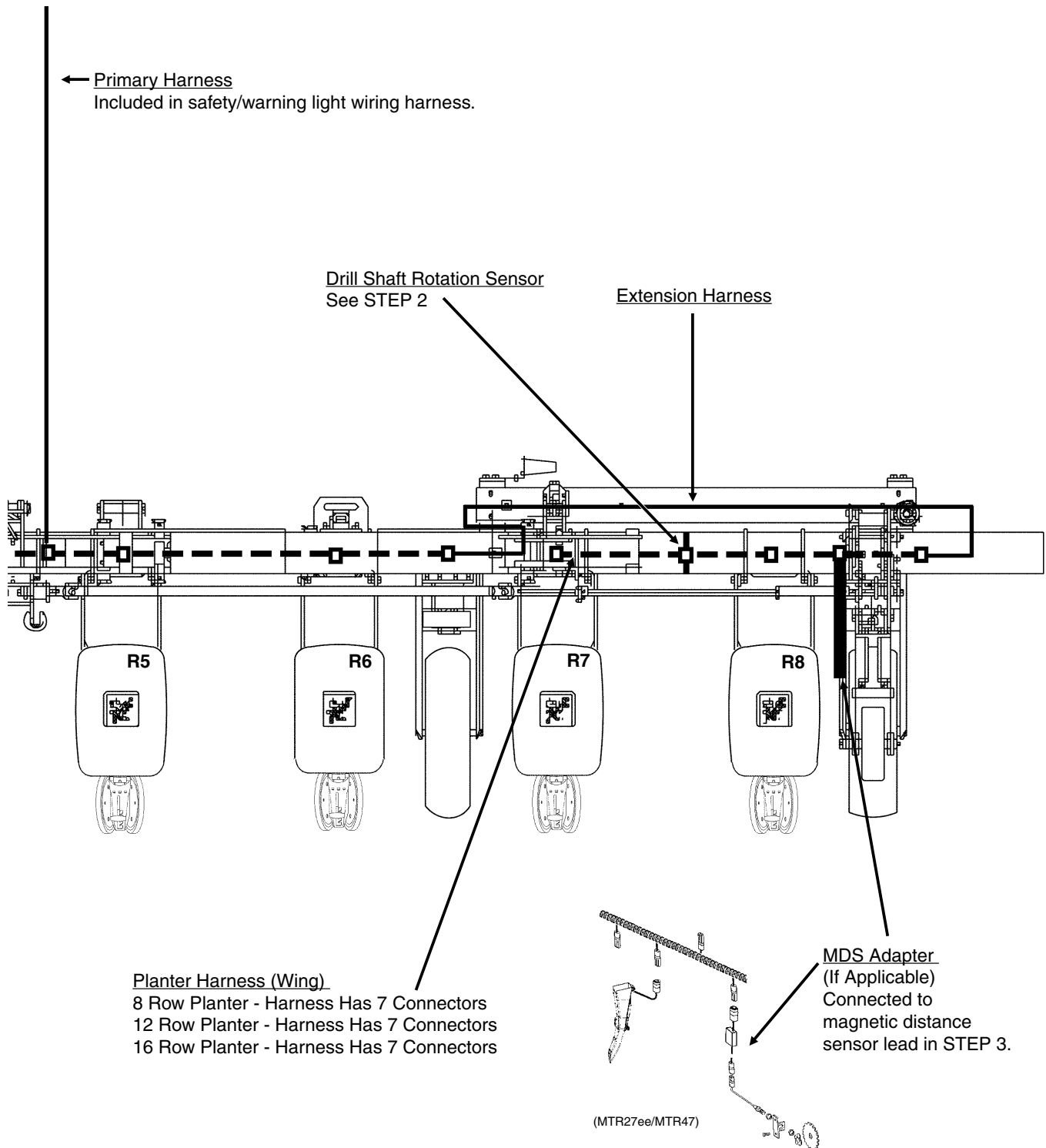

MODEL 3200 FLEX ECONO-FOLD® PLANTER

(12 Row Shown)

(PLTR148b/PLTR148c)

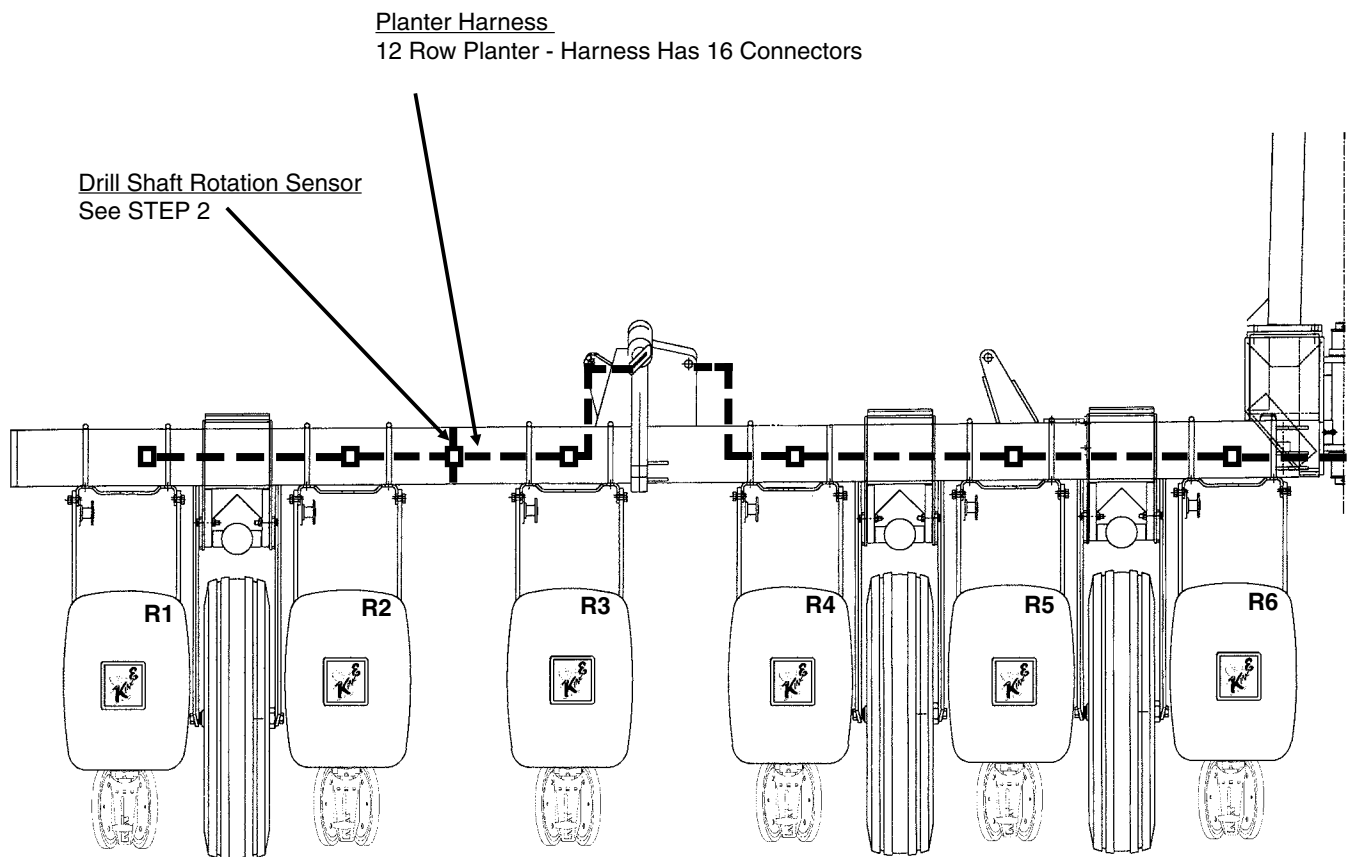

NOTE: If the radar distance sensor is being installed, it is connected to the radar sensor cable on the console and the extra connector on the planter harness is not used. If the magnetic distance sensor is being installed, it is connected to the planter harness and the sensor cable on the console is not used. Bundle and tie any unused harness connectors to the harness so they will not be damaged. **DO NOT** connect distance sensor or seed tubes at this time.

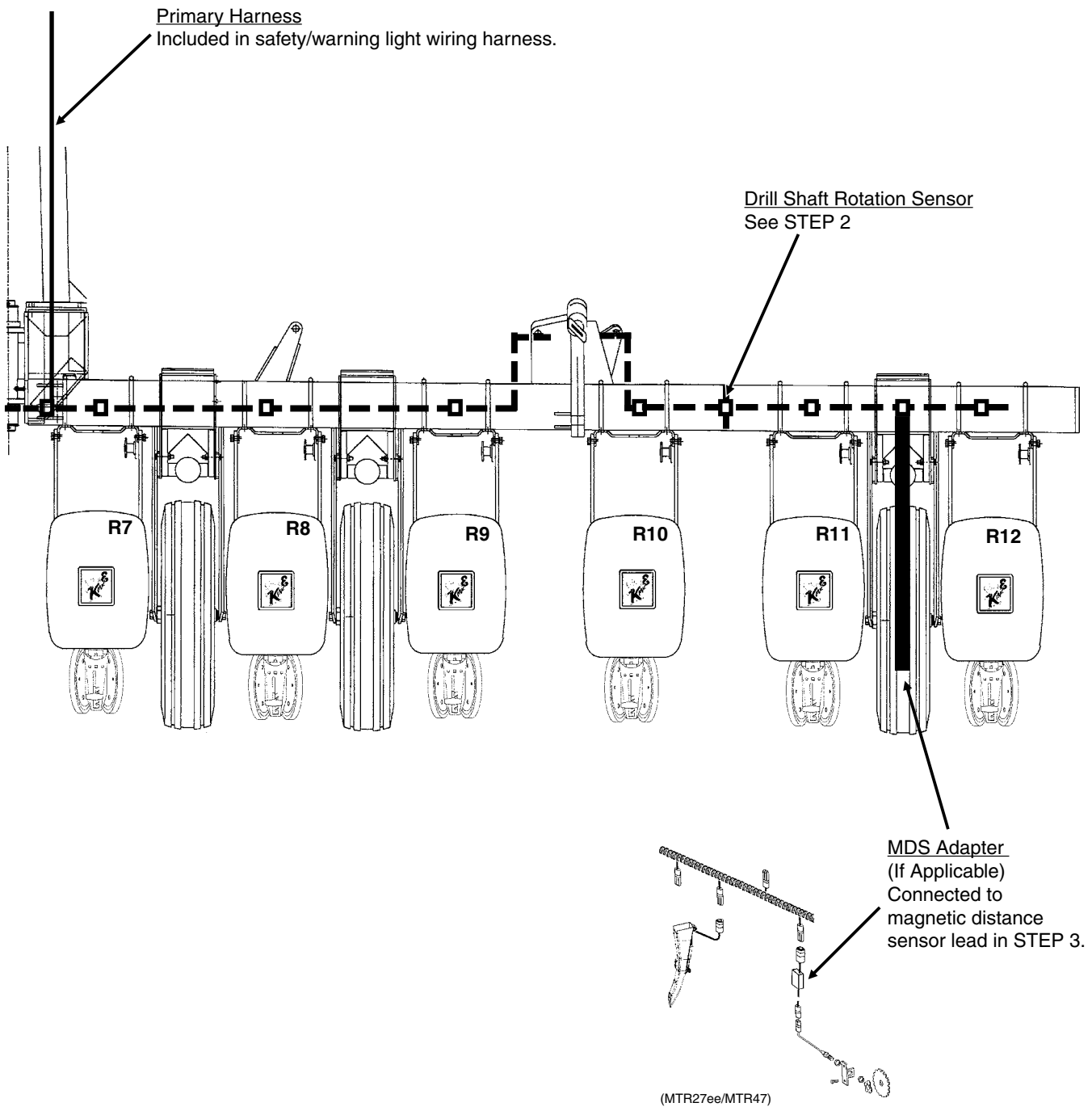

MODEL 3400 TWIN-LINE® PLANTER WITH INTERPLANT® PACKAGE

(12 Row With 11 Push Row Units Shown)

(PLTR147/MTR27ee/MTR47)

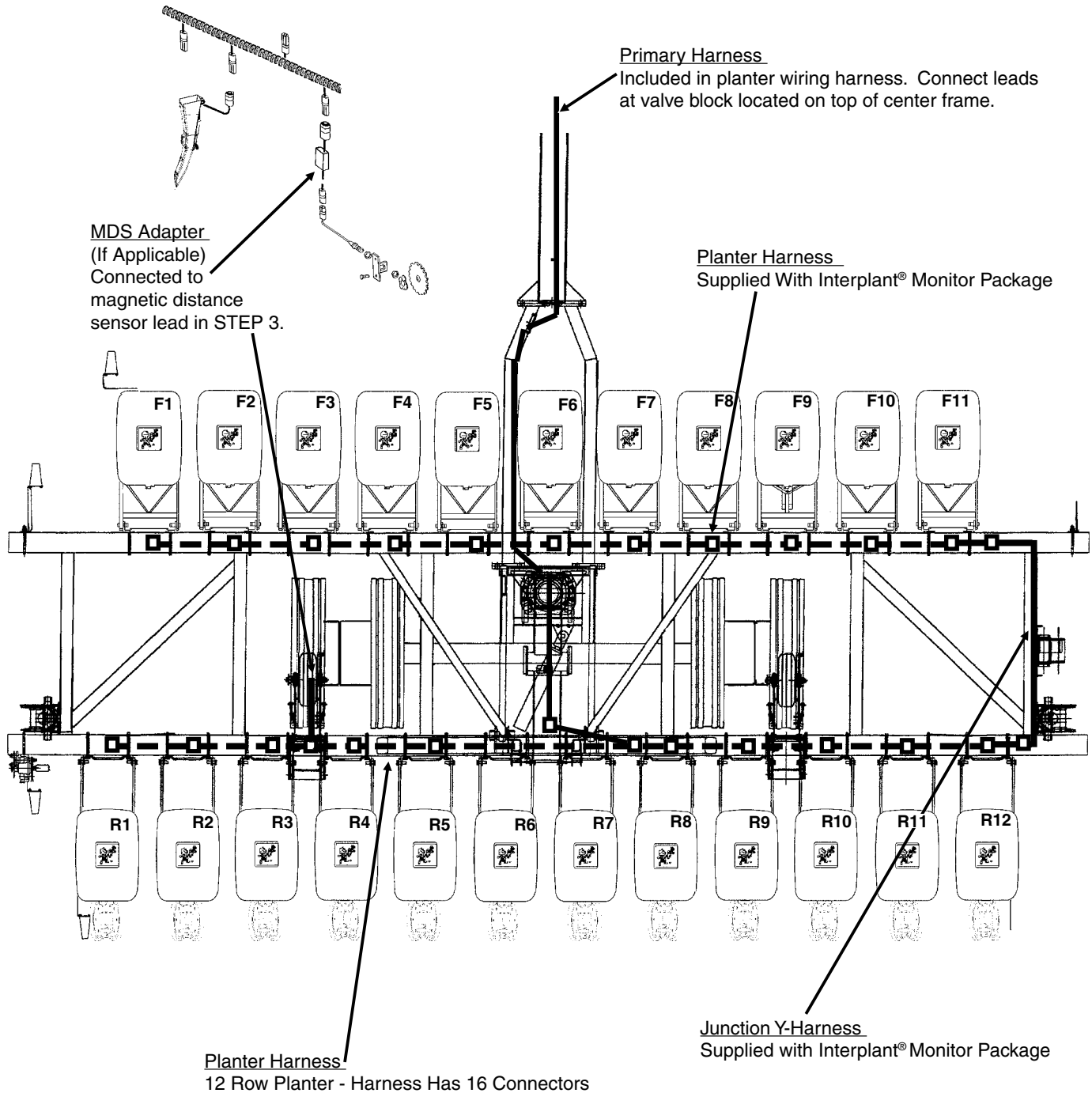

NOTE: If the radar distance sensor is being installed, it is connected to the radar sensor cable on the console and the extra connector on the planter harness is not used. If the magnetic distance sensor is being installed, it is connected to the planter harness and the sensor cable on the console is not use. Bundle and tie any unused harness connectors to the harness so they will not be damaged. **DO NOT** connect distance sensor or seed tubes at this time.

MODEL 3500 TWIN-LINE® PLANTER WITH INTERPLANT® PACKAGE

(8 Row With 7 Push Row Units Shown)

(PLTR121r)

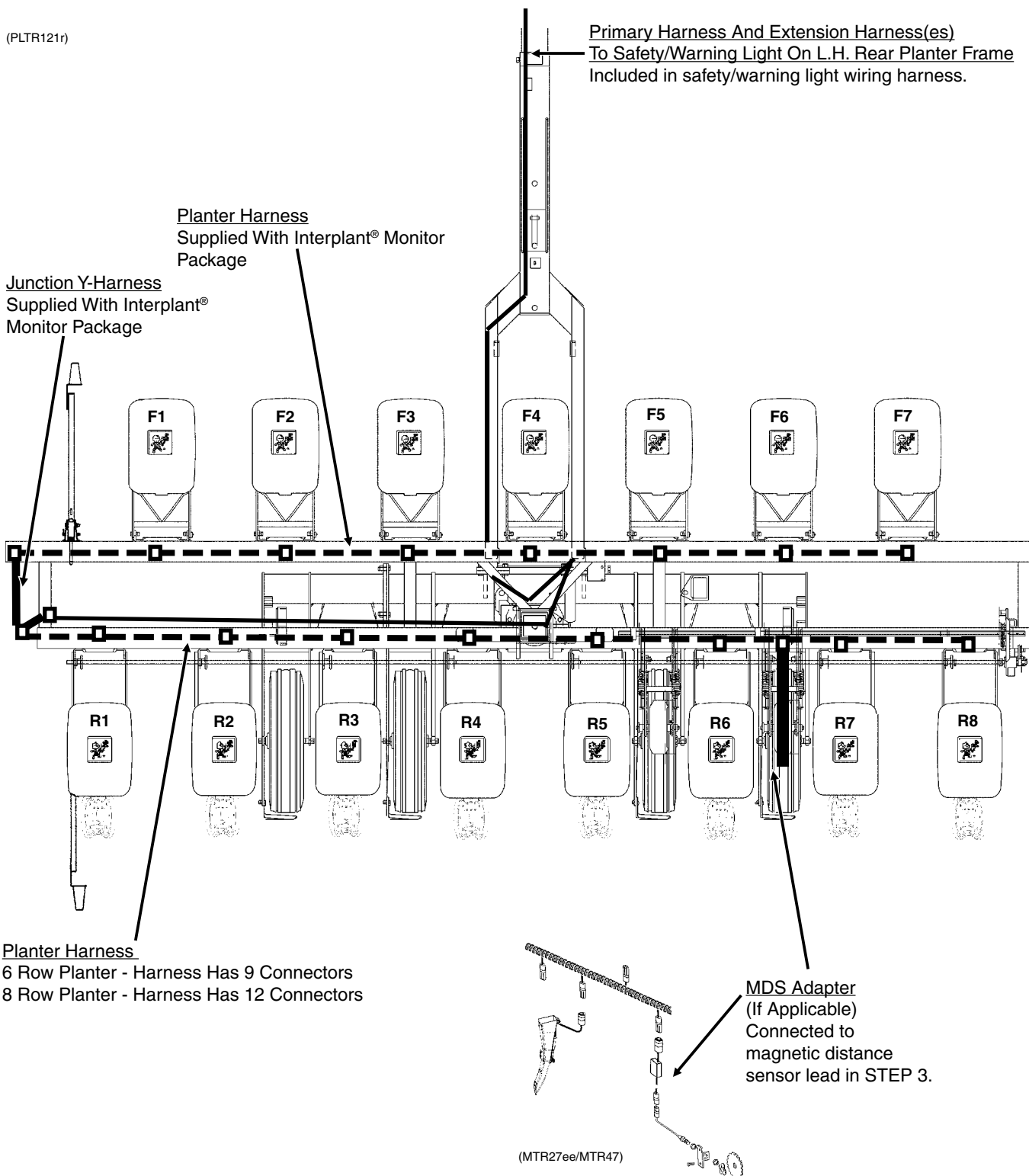

Planter Harness
 6 Row Planter - Harness Has 9 Connectors
 8 Row Planter - Harness Has 12 Connectors

NOTE: If the radar distance sensor is being installed, it is connected to the radar sensor cable on the console and the extra connector on the planter harness is not used. If the magnetic distance sensor is being installed, it is connected to the planter harness and the sensor cable on the console is not used. Bundle and tie any unused harness connectors to the harness so they will not be damaged. **DO NOT** connect distance sensor or seed tubes at this time.

MODEL 3600 TWIN-LINE® PLANTER WITH INTERPLANT® PACKAGE

(12 Row With 11 Push Row Units Shown)

(PLTR132h/PLTR132d)

Drill Shaft Rotation Sensor
See STEP 2

NOTE: On 8 and 12 row sizes equipped with Interplant® Package, the drill shaft rotation sensors will have to be installed on the 2nd row in on each side of the planter to avoid interference with the Interplant® Package drive.

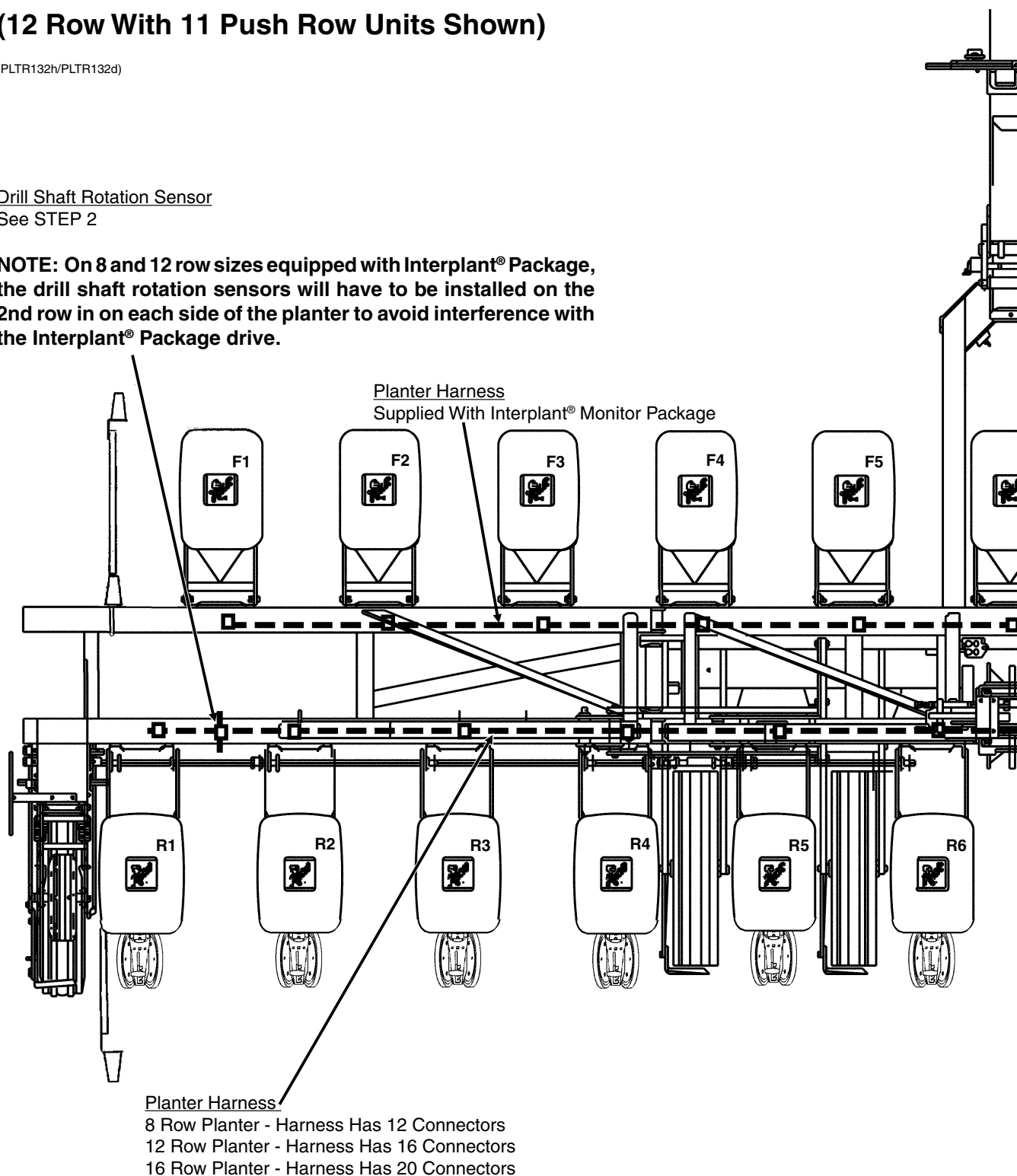

NOTE: If the radar distance sensor is being installed, it is connected to the radar sensor cable on the console and the extra connector on the planter harness is not used. If the magnetic distance sensor is being installed, it is connected to the planter harness and the sensor cable on the console is not used. Bundle and tie any unused harness connectors to the harness so they will not be damaged. DO NOT connect distance sensor or seed tubes at this time.

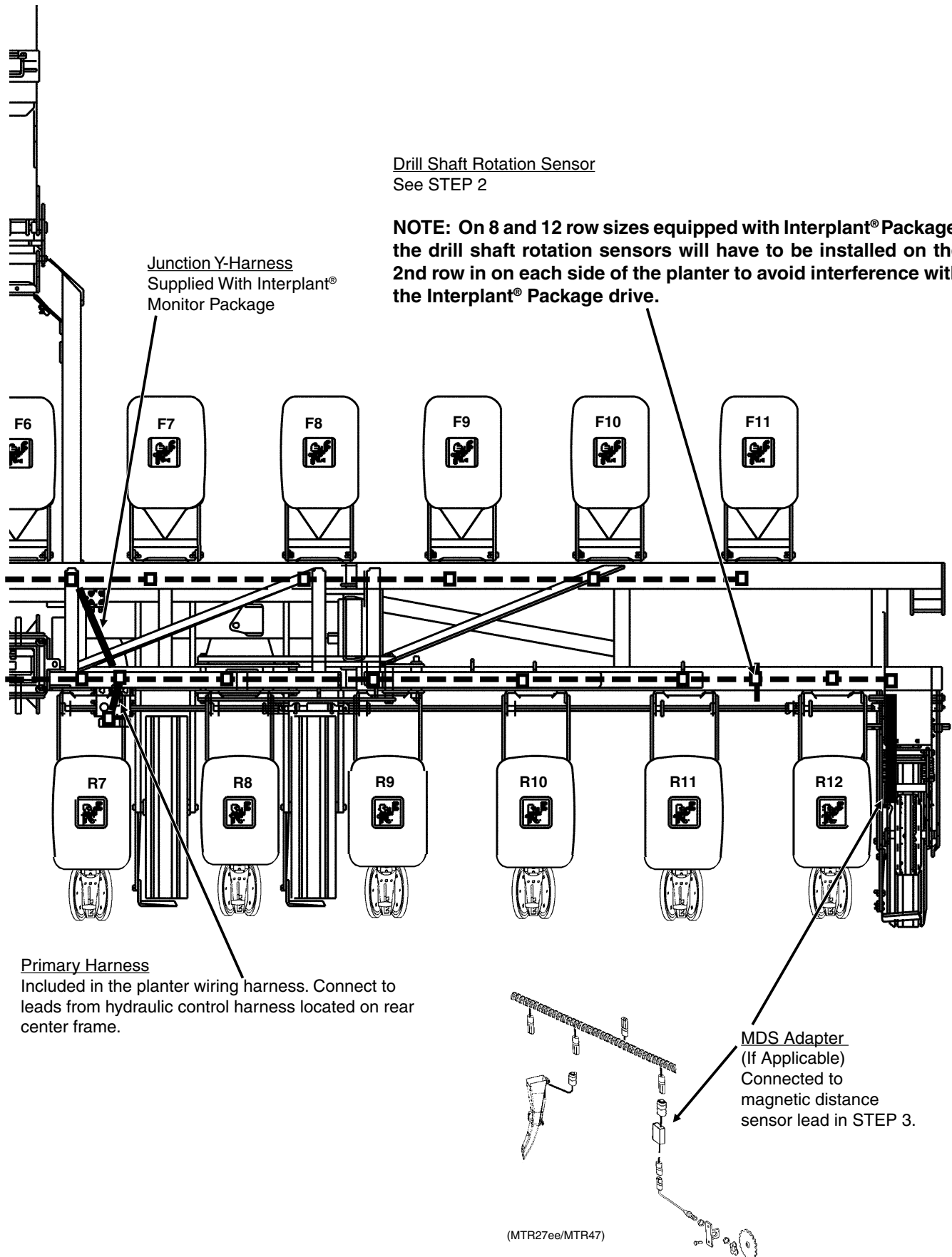

MODEL 3600TR TWIN-LINE® PLANTER

(16 Row Shown)

(TWL186)

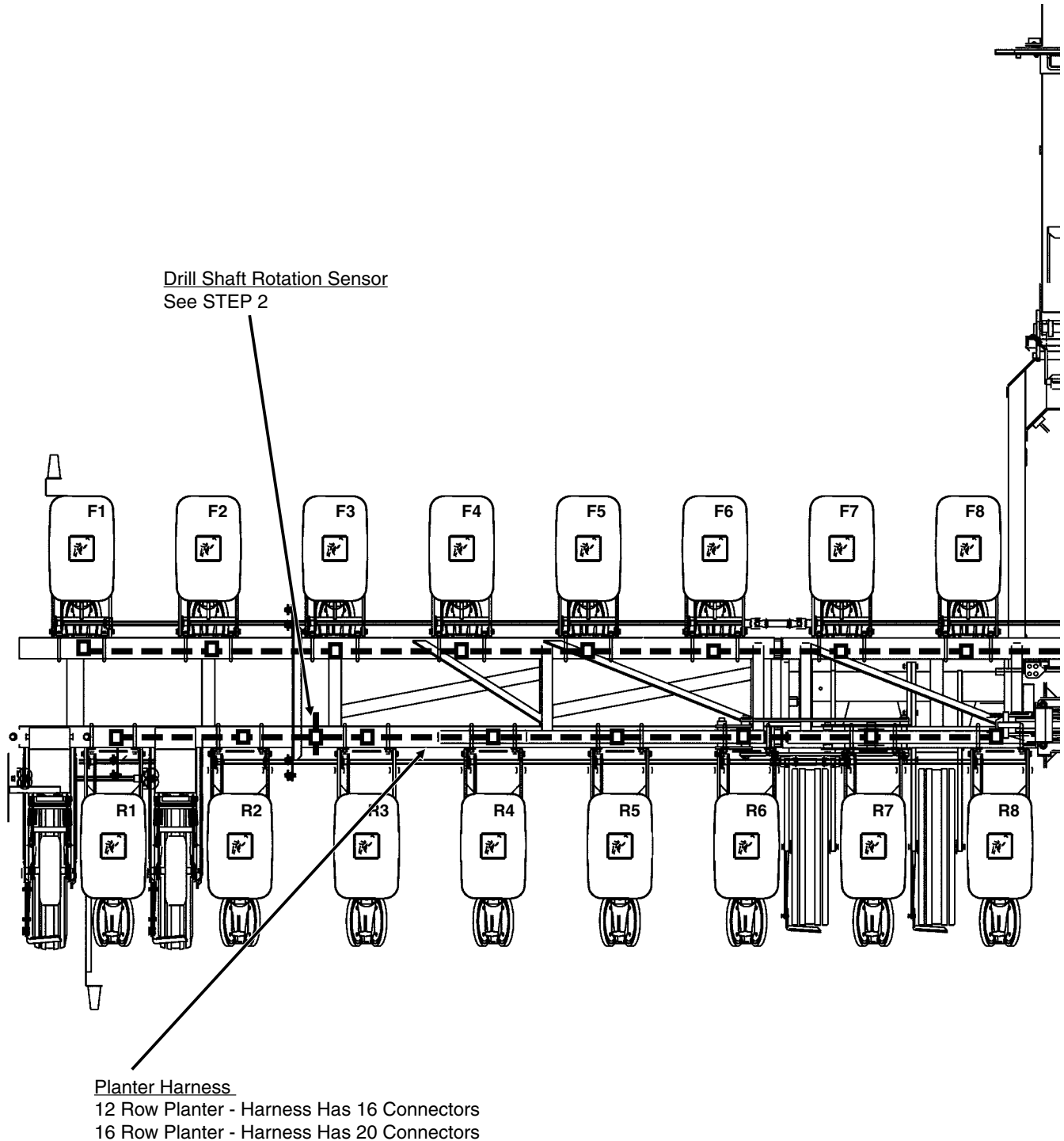

NOTE: If the radar distance sensor is being installed, it is connected to the radar sensor cable on the console and the extra connector on the planter harness is not used. If the magnetic distance sensor is being installed, it is connected to the planter harness and the sensor cable on the console is not used. Bundle and tie any unused harness connectors to the harness so they will not be damaged. **DO NOT** connect distance sensor or seed tubes at this time.

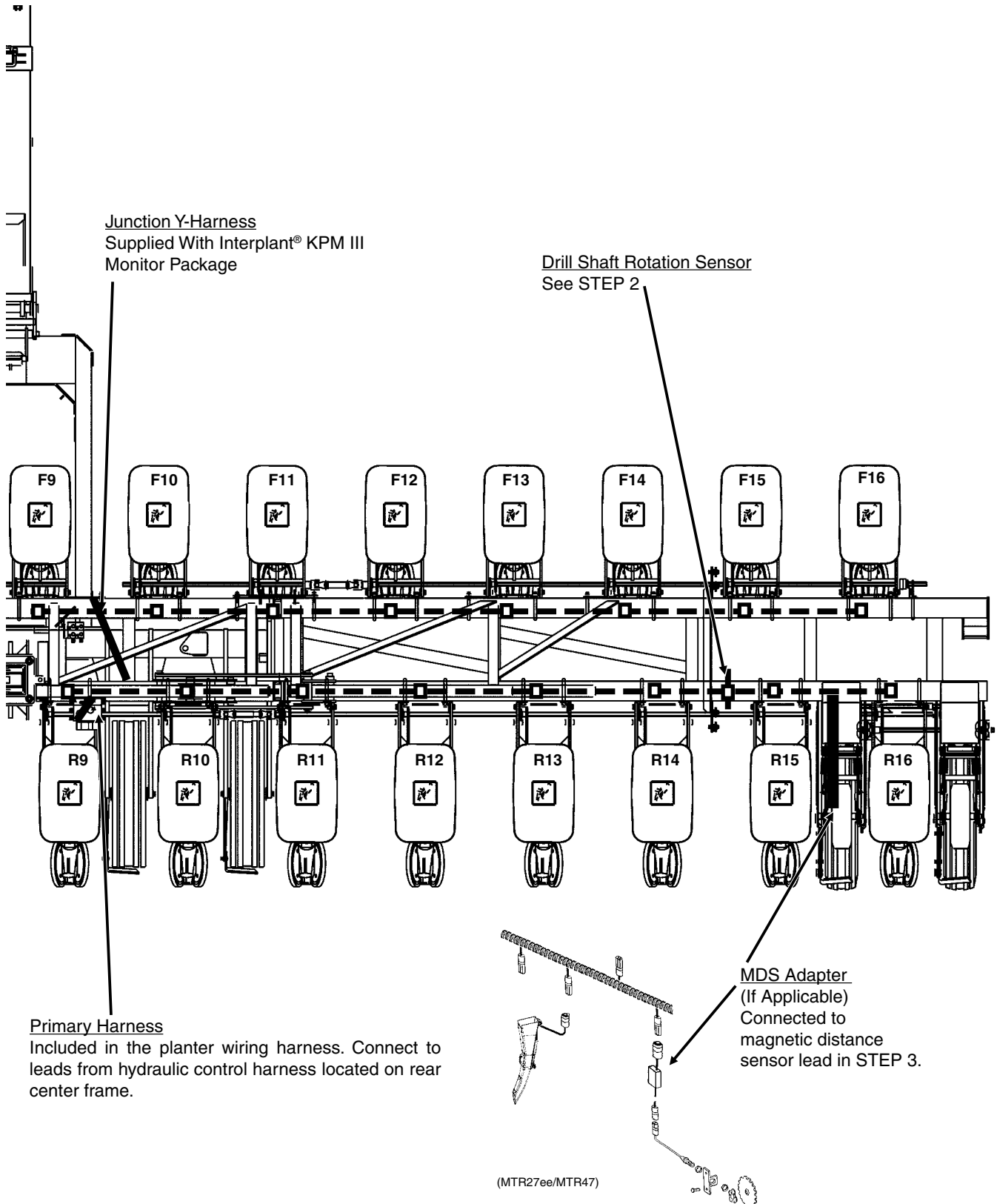

MODEL 3650 TWIN-LINE® PLANTERS WITH INTERPLANT® PACKAGE

(Model 3650 SDS 12 Row With 11 Push Row Units Shown)

(TWL254)

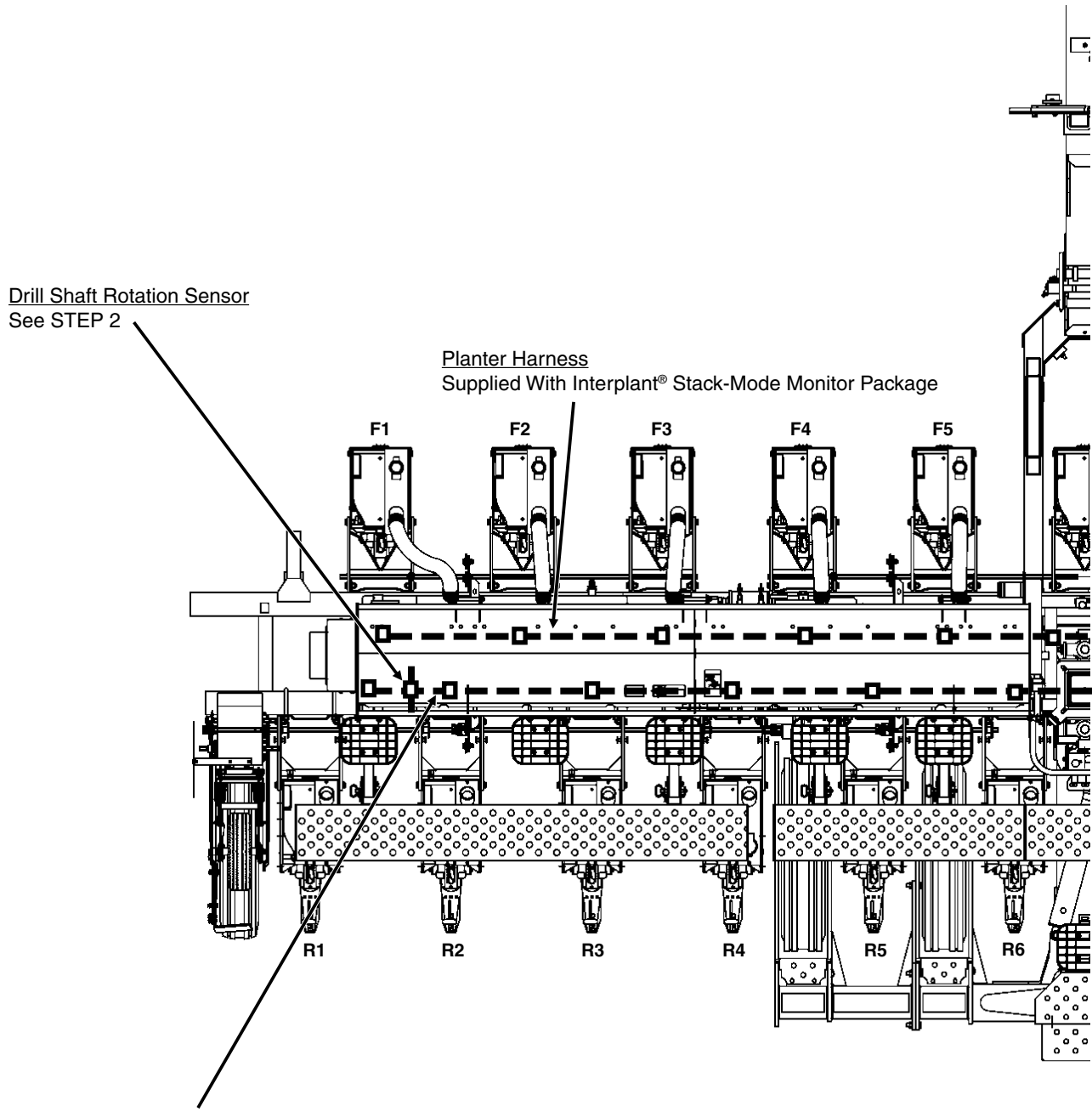

Planter Harness
 12 Row Planter - Harness Has 16 Connectors
 16 Row Planter - Harness Has 20 Connectors

NOTE: If the radar distance sensor is being installed, it is connected to the radar sensor cable on the console and the extra connector on the planter harness is not used. If the magnetic distance sensor is being installed, it is connected to the planter harness and the sensor cable on the console is not used. Bundle and tie any unused harness connectors to the harness so they will not be damaged. **DO NOT** connect distance sensor or seed tubes at this time.

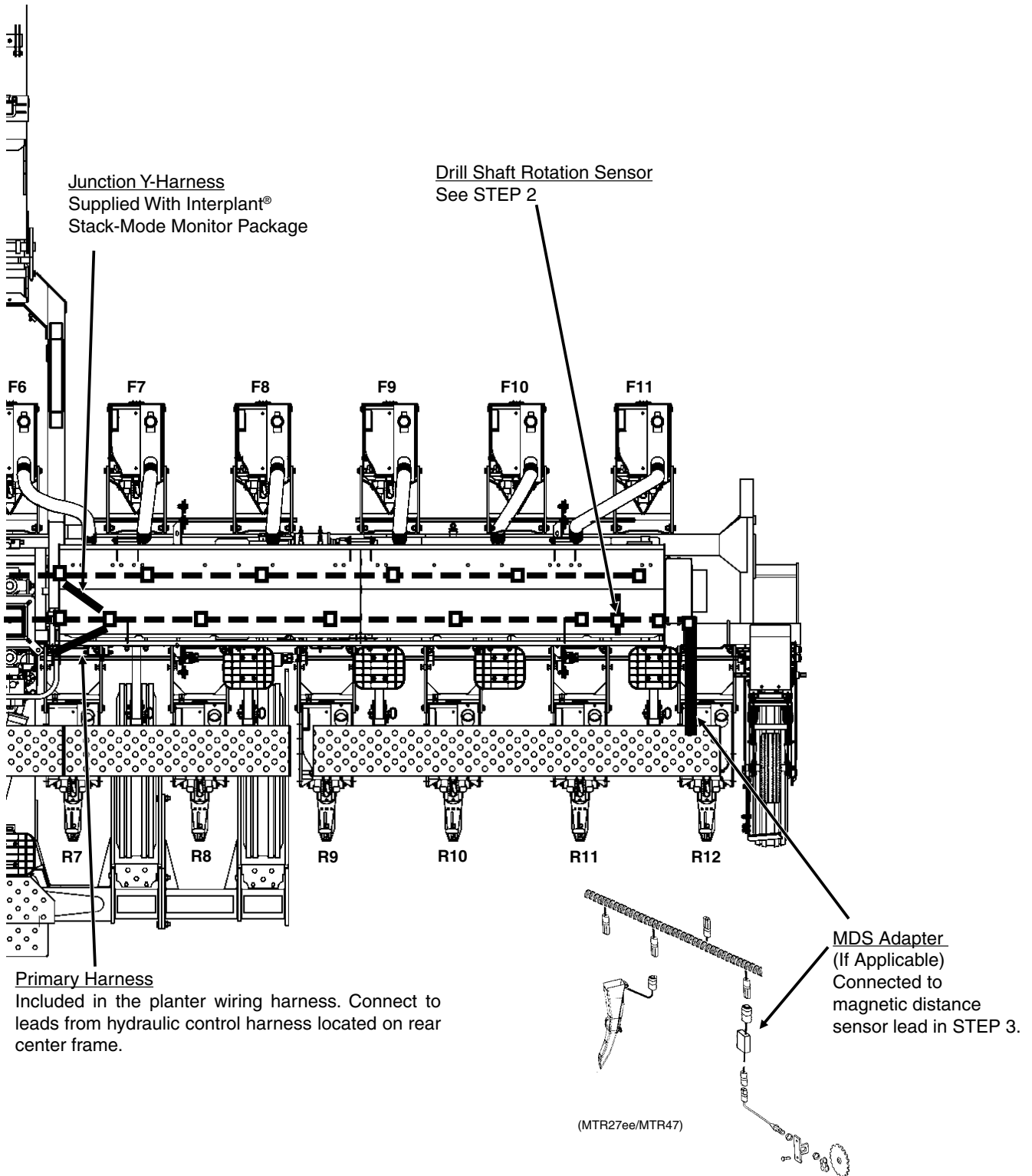

MODEL 3700 FRONT FOLDING PLANTER

(24 Row 30" Shown)

(FF94)

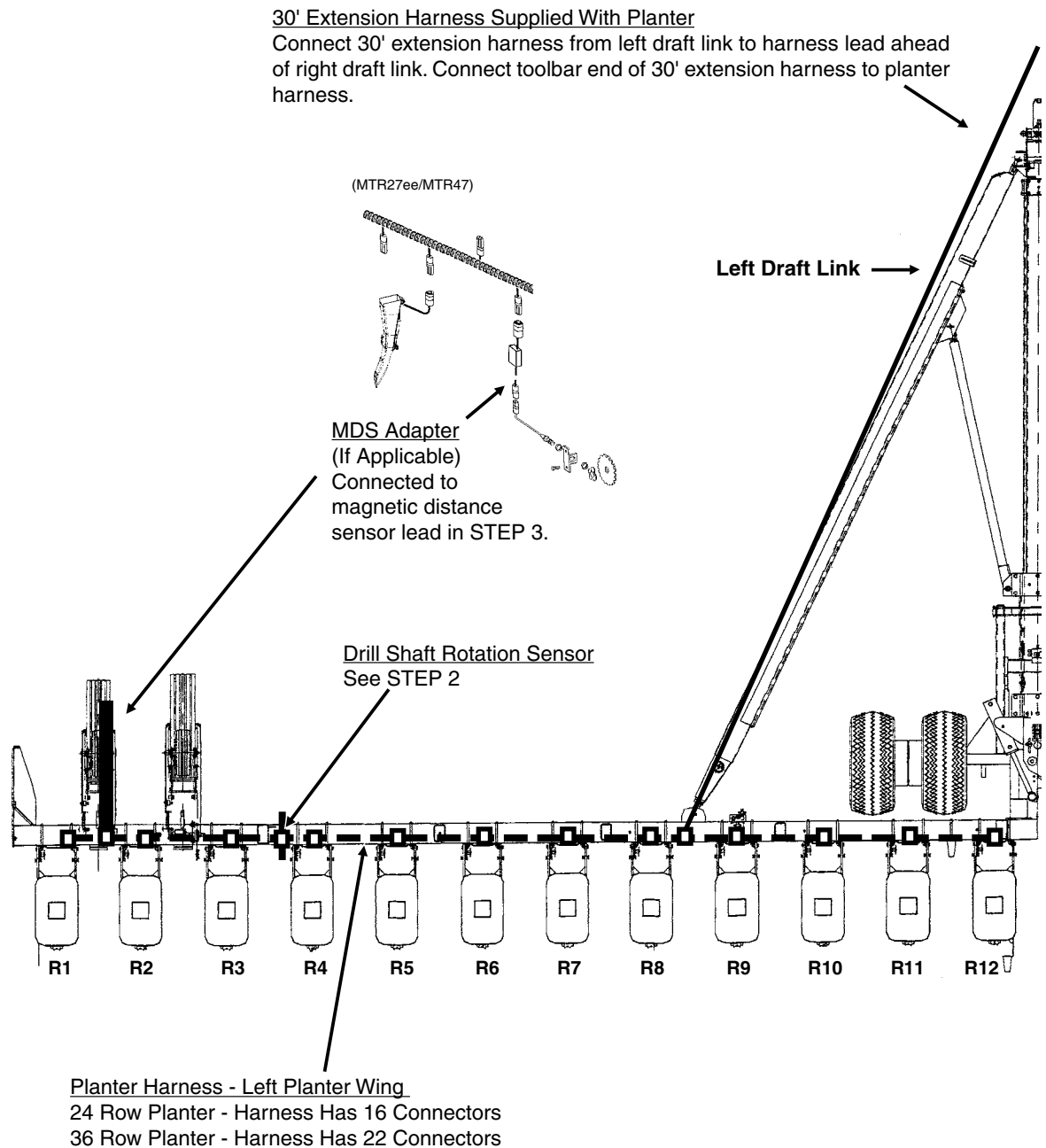

NOTE: If the radar distance sensor is being installed, it is connected to the radar sensor cable on the console and the extra connector on the planter harness is not used. If the magnetic distance sensor is being installed, it is connected to the planter harness and the sensor cable on the console is not used. Bundle and tie any unused harness connectors to the harness so they will not be damaged. **DO NOT** connect distance sensor or seed tubes at this time.

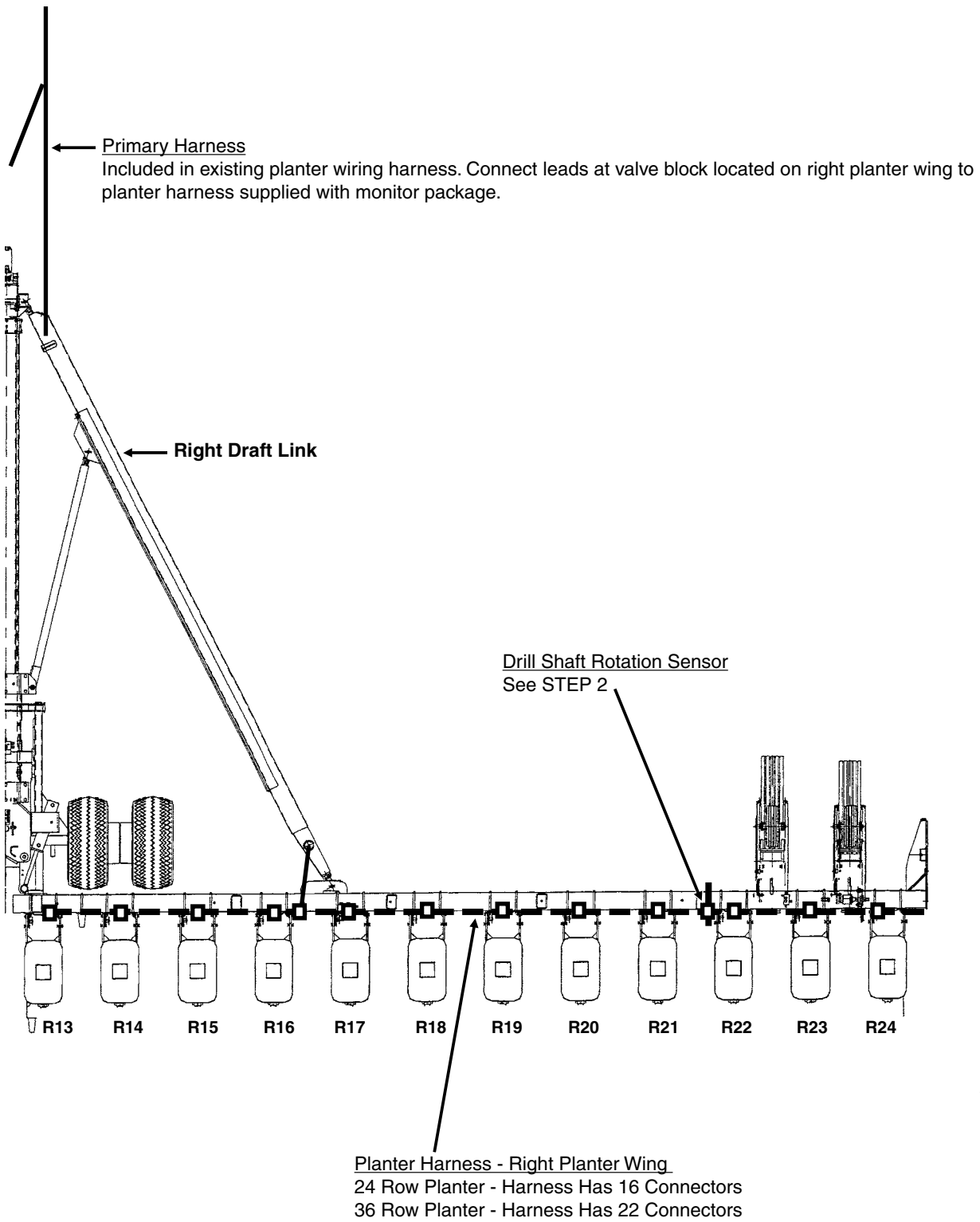

MODEL 3800 FORWARD FOLDING PLANTER

(32 Row 30" Shown)

(FDW4a)

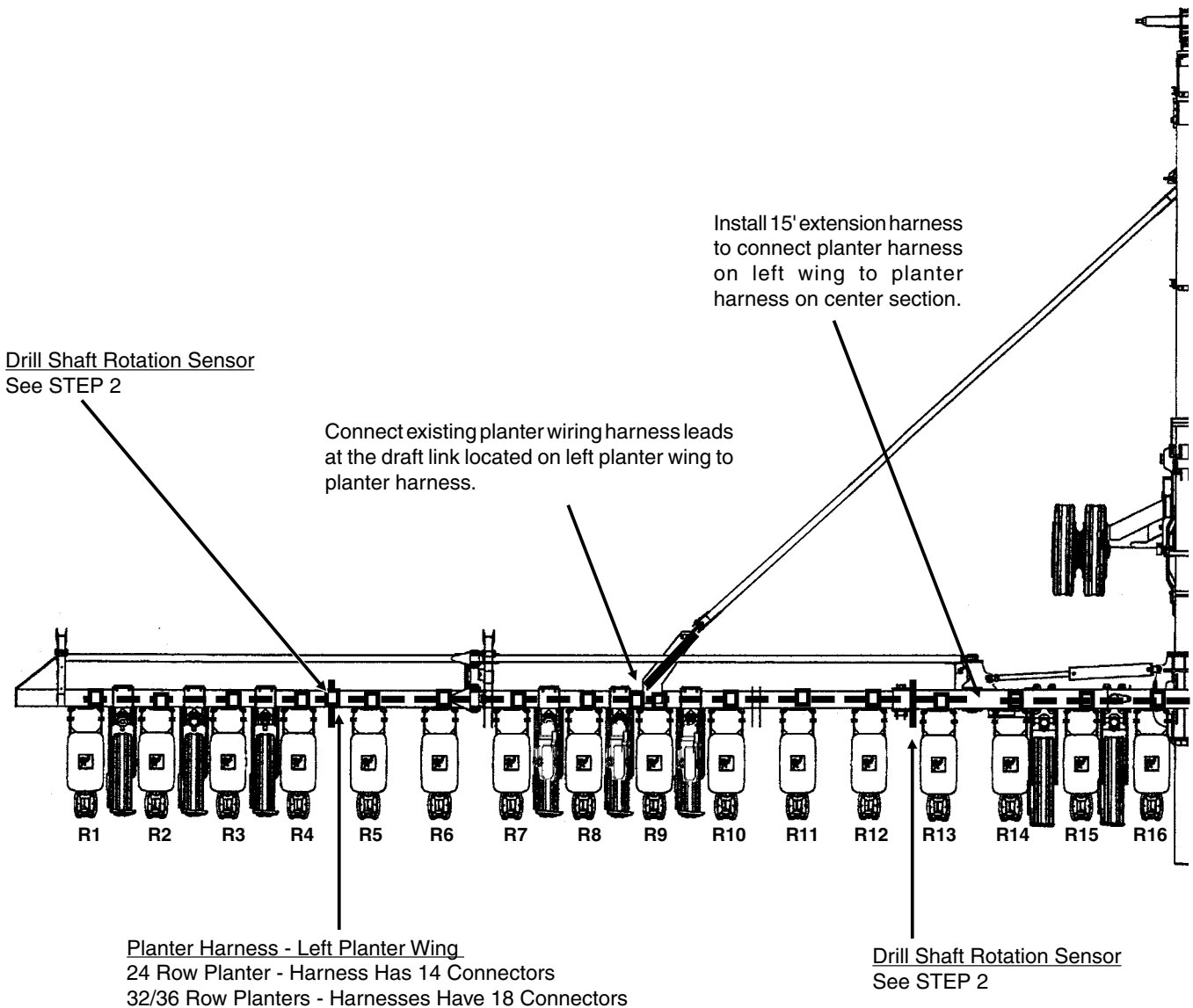

NOTE: If the radar distance sensor is being installed, it is connected to the radar sensor cable on the console and the extra connector on the planter harness is not used. If the magnetic distance sensor is being installed, it is connected to the planter harness and the sensor cable on the console is not used. Bundle and tie any unused harness connectors to the harness so they will not be damaged. **DO NOT** connect distance sensor or seed tubes at this time.

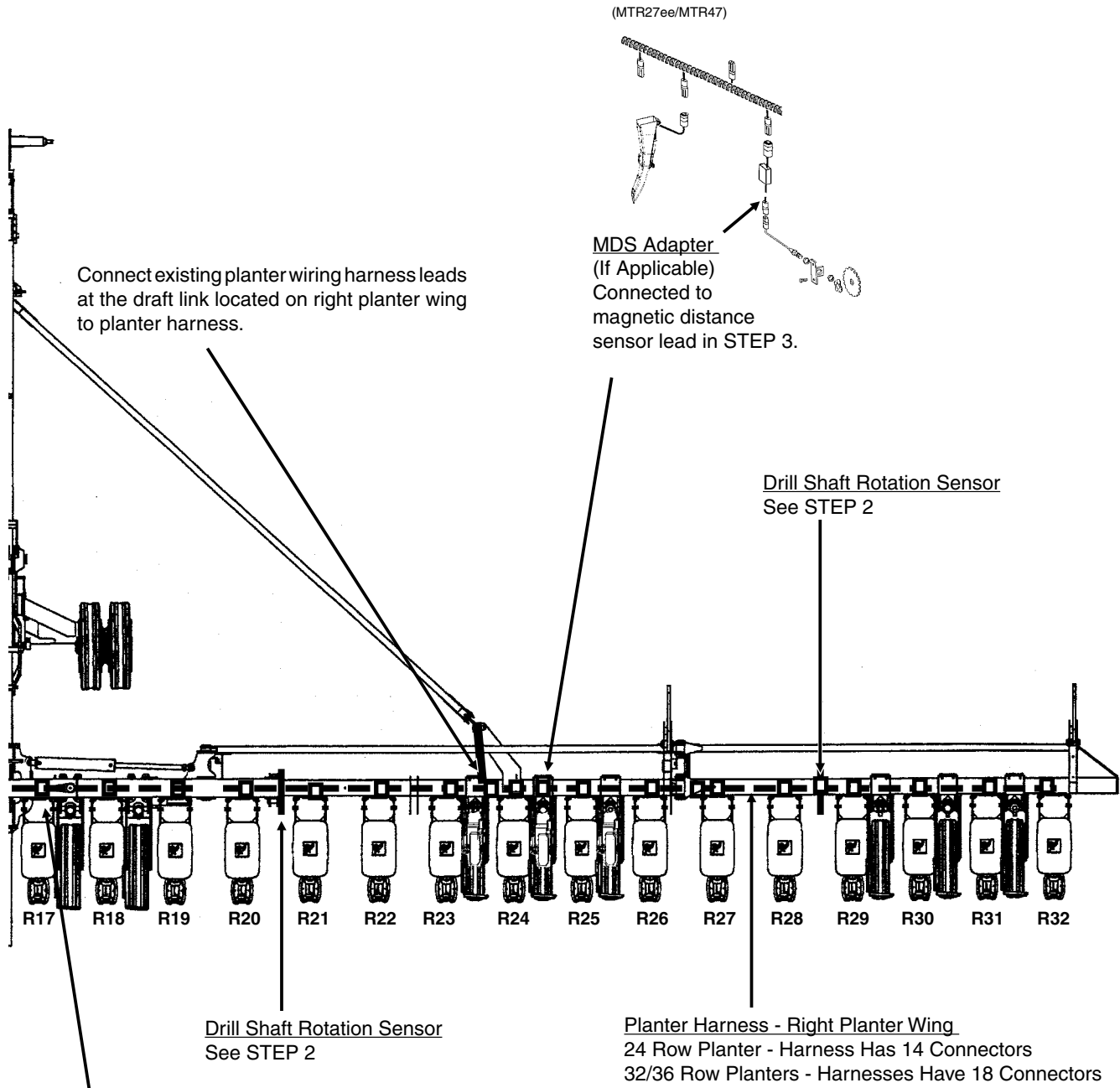

INTRODUCTION

D10190501



The KPM III electronic seed monitor system consists of (a) a KPM III console, which is mounted on the tractor; (b) seed tubes with sensors, one of which is installed in each planter row unit; (c) a magnetic distance sensor, which is installed on the planter, or a radar distance sensor, which is installed on the tractor; (d) shaft rotation sensors (if applicable), which are installed on the planter drill shafts; and (e) planter harnesses (junction Y-harness and/or extension harness where applicable), to which the individual seed tube sensors connect. The primary harness, which connects the monitor console to the planter harness, is hard-wired into the safety/warning light harness or control console harness included as standard equipment with the planter.

The software design of the KPM III console allows simultaneous viewing of seed flow bargraphs for standard and/or Interplant® System rows (up to 36 rows).

The monitor system is powered by the tractor battery (requires 12 volts DC). The console receives information from each of the sensors and displays this information.

The KPM III console uses a single backlit Liquid Crystal Display (LCD) to show, the number of monitored rows, the relative seed rate for each row (using bargraph displays) and displays various alarm and warning messages when an alarm condition exists. A continuous audible alarm will sound upon system malfunction or underflow conditions for any monitored row. Alarms must be acknowledged by the user. Various warnings may sound the alarm or flash one or more messages. The LCD also shows alphanumeric data such as row spacing, units (Metric or English), speed (MPH or KM/H), volume, seed population, seed spacing, field area and total area.

The monitor system will power down if no activity is detected within one hour. No activity means there has been no new seed flow and no operator push key input.

MONITOR KEY FUNCTIONS

Push keys allow the user to select or change the operating mode, the active displays or the current configuration. Depending on the operating mode or the current display selected, some keys may not be active. Each key press, if valid, is acknowledged by a short beep and an action is taken. If the key press has no action associated, the key press is considered invalid, and the user will not receive feedback.

D10190501

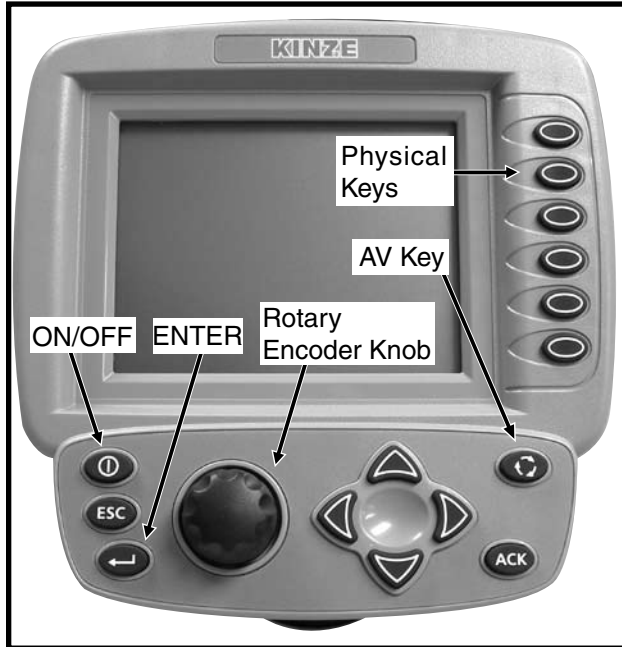

PHYSICAL KEYS

- Located on R.H. side of console and referred to as F1, F2, F3, F4, F5 and F6
- Keys are referenced in descending order with F1 at the top and F6 at the bottom.



ON/OFF KEY

- Powers the unit on and off.



ESC KEY

- Used as the CANCEL (escape) key.



ENTER KEY

- Confirms or accepts the highlighted selection.



ROTARY ENCODER KNOB

- Turn knob clockwise to increase or counterclockwise to decrease value of item.
- Turn knob clockwise to scroll up or counterclockwise to scroll down.
- Press knob to enter selection.

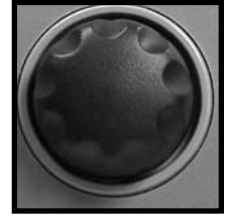

AV (AUDIO/VIDEO) KEY

- Set alarm volume.
- Adjust the contrast.
- Adjust backlighting of the LCD display.



ACK (ACKNOWLEDGE) KEY

- Used to silence (acknowledge) the warning alarm when various error conditions occur.

NOTE: Alarms can be viewed by pressing the STATUS key.



ARROW KEYS

- UP arrow key is used to increase the value of an item by one or to scroll up.
- DOWN arrow key is used to decrease the value of an item by one or to scroll down.
- LEFT arrow key multiplies the numeric value of the item by 10.
- RIGHT arrow key divides the numeric value of the item by 10.



NOTE: Within the LCD, the black box around the smaller box as shown below indicates which field is selected/highlighted. Turning the rotary encoder knob or pressing the UP or DOWN arrow keys moves the black box. When the black box is positioned on a programmable item, such as Shaft Sensors, Speed Sensor, Front Row Units or Rear Row Units, pressing the knob or ENTER key will highlight the programmable item. A programmable item may only be changed when it is highlighted.

D02140616

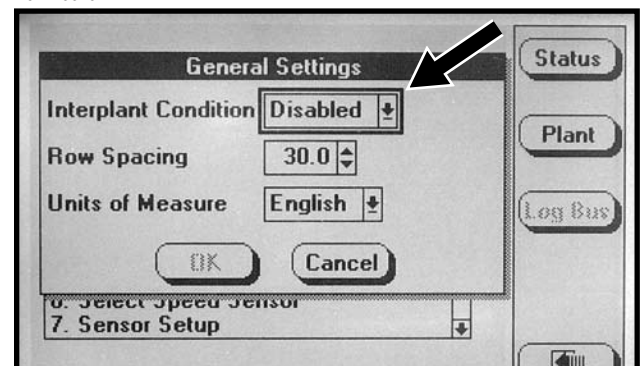

CONFIGURING PLANTER MONITOR

When the KPM III is powered on for the first time it will go directly into the “Planter Configuration” screen (STEP 4).

STEP 1 Press the F6 key until “Mode Selection” screen appears.

D02140614

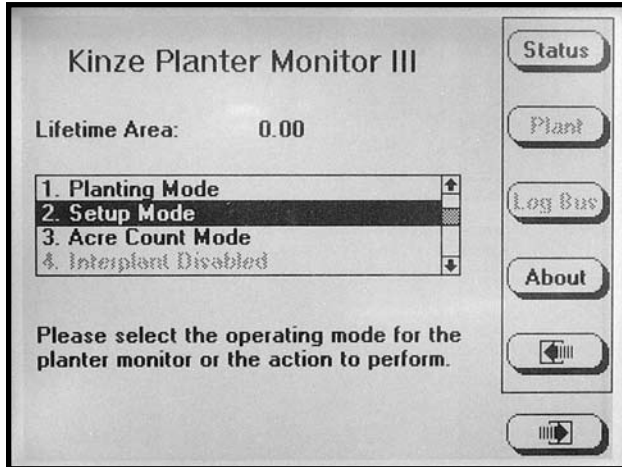

STEP 2 Select “Setup Mode” by turning the rotary encoder knob or using the UP or DOWN arrow keys. Press the knob or ENTER key to display highlighted item.

STEP 3 Select “Configure Planter Monitor” by turning the knob or using the UP and DOWN arrow keys. Press the knob or the ENTER key to display the highlighted item.

D02140624

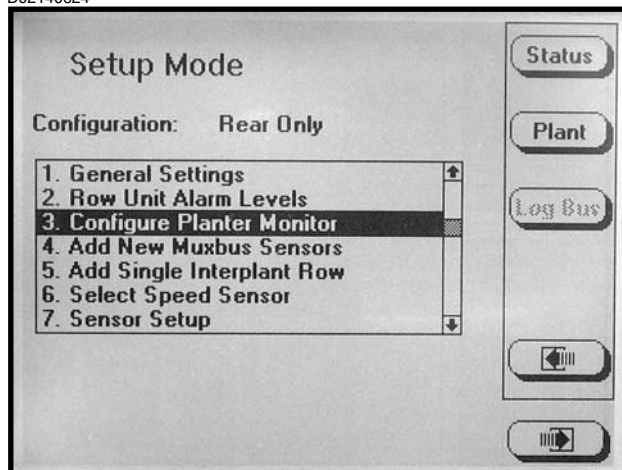

NOTE: The planter monitor cannot be reconfigured while planting.

NOTE: If the monitor has already been configured the message shown below will appear.

D02140634

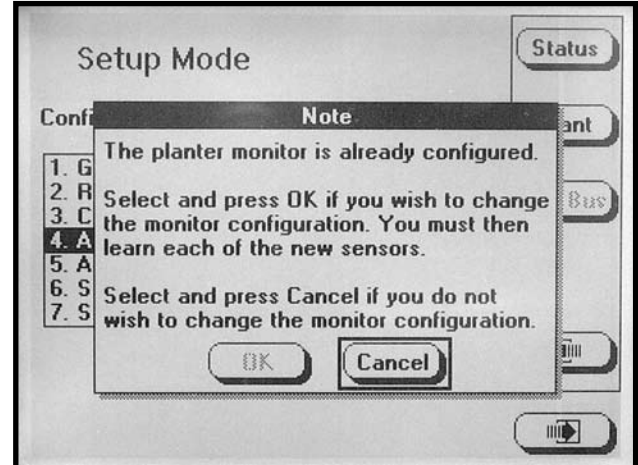

STEP 4 Press the knob or ENTER key, to highlight the “Shaft Sensors” field. Enter the number of “Shaft Sensors” by turning the knob or using the UP or DOWN arrow keys. When the correct value is displayed press the knob or ENTER key. The black box will advance to “Speed Sensor” field.

D05310601

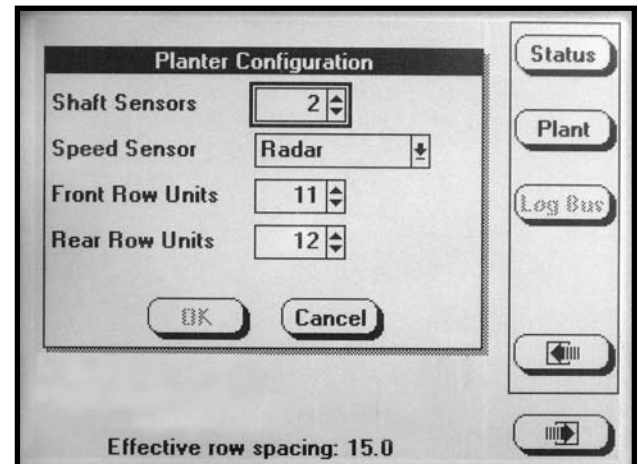

NOTE: The numeric value may be changed only if the item is highlighted. Turning the rotary encoder knob increases or decreases the value of the item. The UP arrow key may be used to increase the value of the item by one and the DOWN arrow key may be used to decrease the value of the field by one.

STEP 5 Press the knob or ENTER key and a drop down menu will appear; select either “Radar” or “Coil Pick-Up” (MDS) by turning the knob or using the UP or DOWN arrow keys. When the desired selection is highlighted press the knob or ENTER key. The black box will advance to “Front Row Units” field.

D05310604

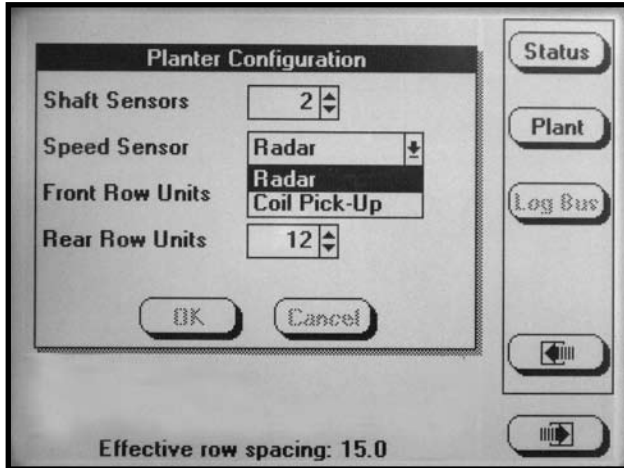

STEP 7 Press the knob or ENTER key to highlight the “Rear Row Units” field. Turn the knob or use the UP or DOWN arrow keys to obtain correct number of pull row units. Press the knob or ENTER key when desired quantity is displayed. The black box will advance to the OK key.

D05310606

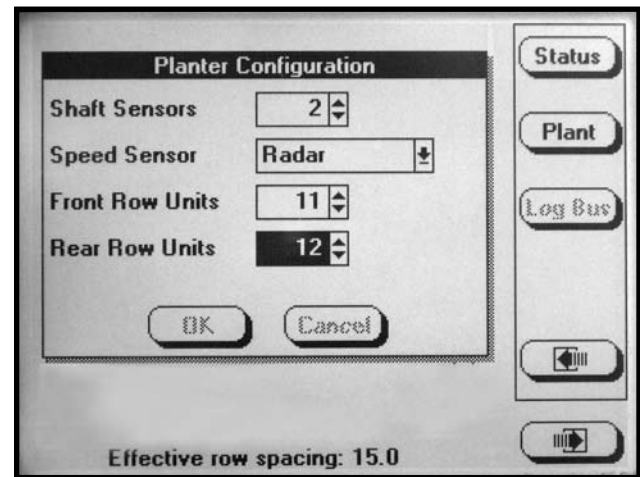

STEP 6 If there are front rows on the planter, press the knob or ENTER key to highlight the “Front Row Units” field. Turn the knob or use the UP or DOWN arrow keys to obtain correct number of push row units. Press the knob or ENTER key when desired quantity is displayed. The black box will advance to “Rear Row Units” field. If no front rows need to be entered simply turn the knob or press the DOWN arrow key to advance to “Rear Row Units”.

STEP 8 Press the knob or the ENTER key to save the information.

D05310607

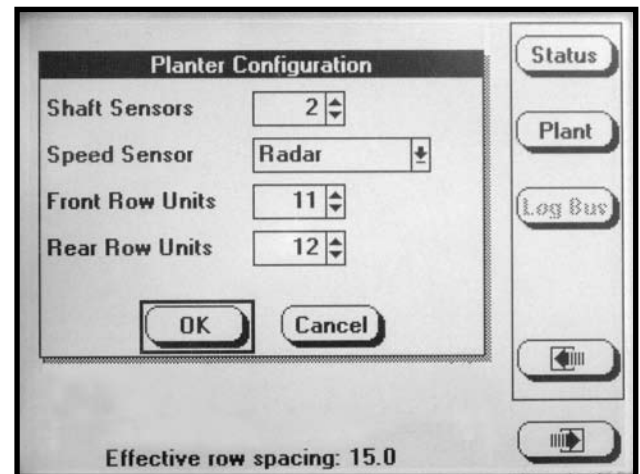

D05310605

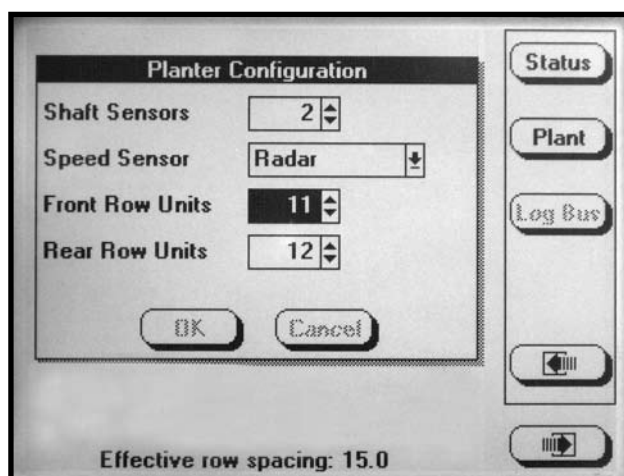

NOTE: To prevent the configuration from being saved press ESC or select the CANCEL button, then press the rotary encoder knob or ENTER key.

STEP 9 The monitor screen shown below will appear.

If the new planter configuration is to be saved turn the knob or press the UP or DOWN arrow keys to select the OK button then press the knob or ENTER key to save the planter configuration into the KPM III. If the monitor configuration is not to be changed select the CANCEL key, press the knob or ENTER key to CANCEL or press the ESC key.

If OK is selected the monitor will advance to "Sensor Setup" (STEP 4 in PROGRAMMING/CONNECTING SEED TUBES, SHAFT ROTATION SENSORS AND/OR RADAR/MAGNETIC DISTANCE SENSORS section).

NOTE: STEP 9 does not apply if configuring the monitor for the first time.

D02140634

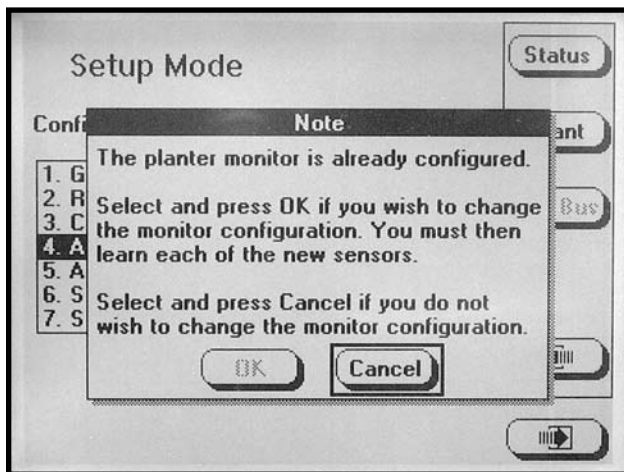

PROGRAMMING/CONNECTING SEED TUBES, SHAFT ROTATION SENSORS AND/OR RADAR/MAGNETIC DISTANCE SENSORS

STEP 1 To enter "Mode Selection", press F6 key until the "Mode Selection" screen appears.

STEP 2 Select "Setup Mode" by turning the rotary encoder knob or press the UP or DOWN arrow keys. Press the knob or ENTER key to display the highlighted item.

STEP 3 Select "Sensor Setup" by turning the knob or using the UP or DOWN arrow keys. Press the knob or ENTER key to display the highlighted item.

D02140641

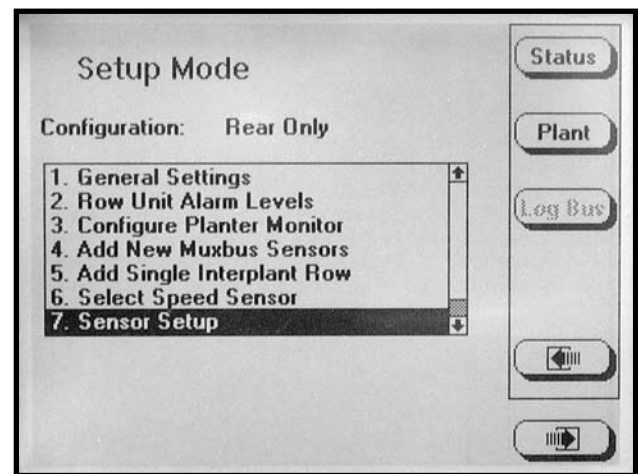

STEP 4 Attach the planter harness to the KPM III. Do NOT connect any of the sensors to the planter harness. With [Auto Detect] selected press the INSTALL key.

D02210601a

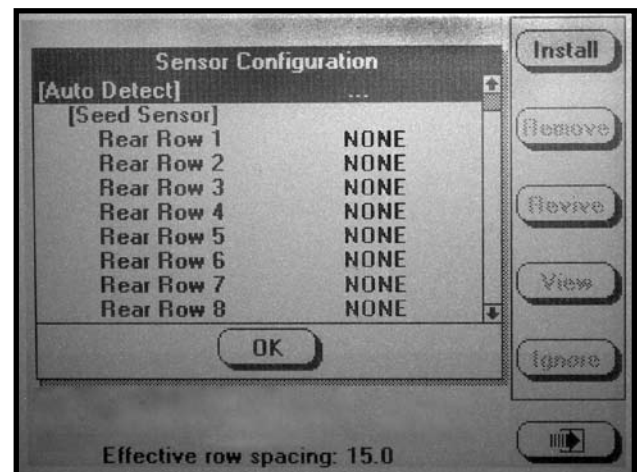

STEP 5 Plug in the first seed sensor (row 1), working from left to right and rear to front (rear row units and front next if applicable). When a sensor is connected to the planter harness wait for the monitor to acknowledge with two beeps.

Continue connecting seed sensors along with shaft rotation sensors or speed sensors. Progress will reflect on the LCD screen. The example below indicates that the last seed sensor found was Front Row 7 and the monitor is looking for the next sensor.

When all sensors are installed press the F1 key to end the installation.

D02170617

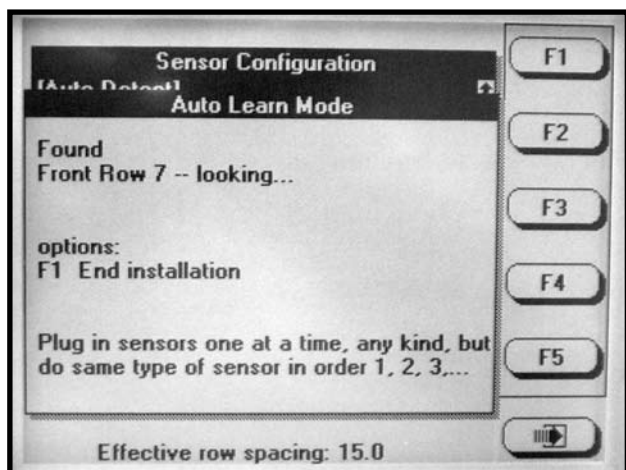

NOTE: After each sensor has been installed “OK” will appear after the sensor name.

D02210601b

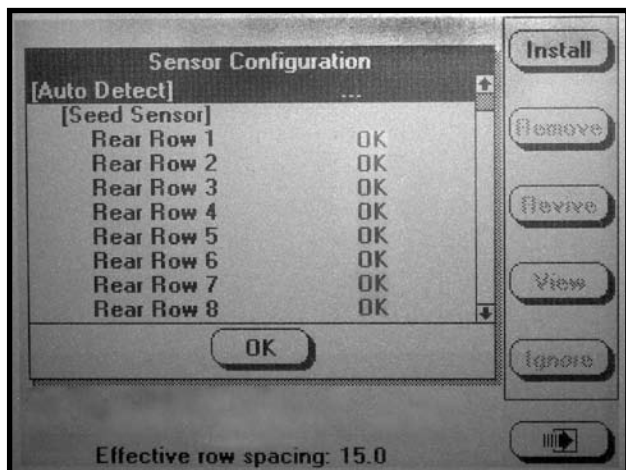

STEP 6 If “OK” appears behind ALL sensors, press the knob or the ENTER key to save the configuration. The “Setup Mode” menu will then appear.

NOTE: If “NONE” appears after a sensor, the sensor was not recognized. All sensors must be disconnected from the planter harness and reconnected as described in STEP 5.

NOTE: If “OK slow” appears after a sensor, the sensor is able to communicate but at a slower speed. For the system to run at top speed of 9600 baud the slow sensor must be replaced.

D05310609

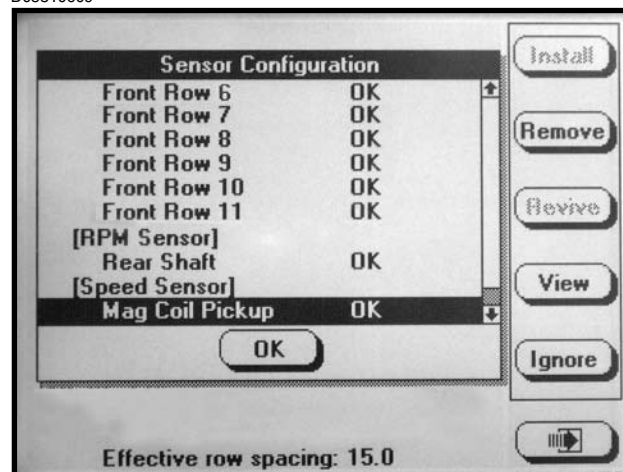

STEP 7 To return to “Planting Mode” select the PLANT key or press the F6 key until “Planting Mode” screen appears.

CHANGING VOLUME, CONTRAST AND BACKLIGHTING

The alarm volume and LCD screen contrast and backlighting may be adjusted at anytime, regardless of what is displayed on the screen.

STEP 1 Press the AV key. The speaker adjustment dialog box will appear in the lower L.H. corner of the display.

D05310610

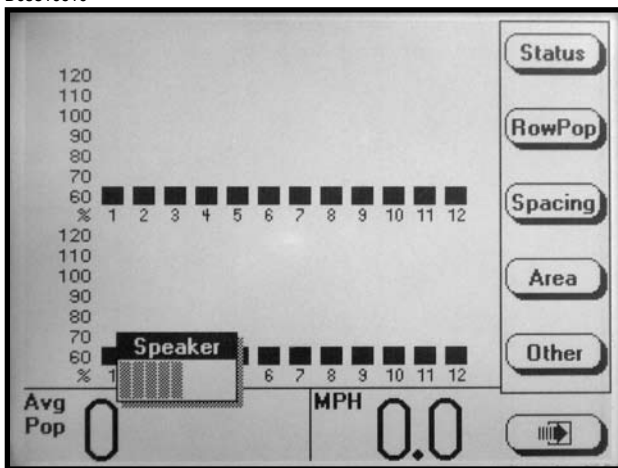

STEP 2 Use the LEFT and RIGHT arrows or turn the rotary encoder knob to adjust the volume. The volume of the sound emitted from the speaker changes as the adjustment is being made.

STEP 3 To adjust contrast or backlight, go to STEP 4. If finished press ENTER to save and exit.

STEP 4 Press the AV button a second time. The contrast adjustment dialog box will appear in the lower portion of the display.

D05310611

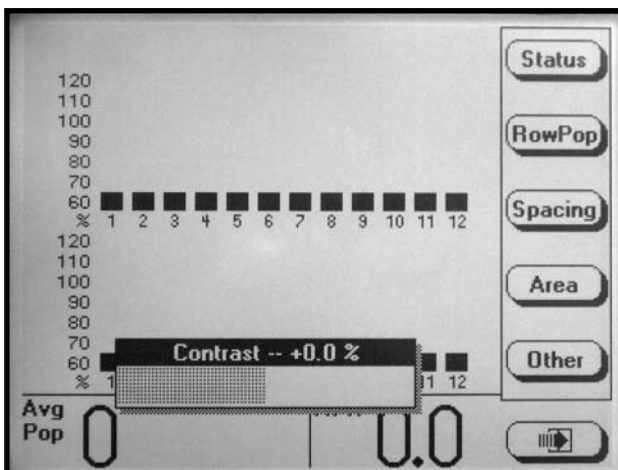

STEP 5 Use the LEFT and RIGHT arrows or turn the knob to adjust contrast. The effect of the adjustment will be visible on the display.

STEP 6 To adjust backlighting go to STEP 7. If finished press ENTER to save and exit.

STEP 7 Press the AV button a third time. The backlight adjustment dialog box will appear in the lower L.H. corner of the display.

D05310612

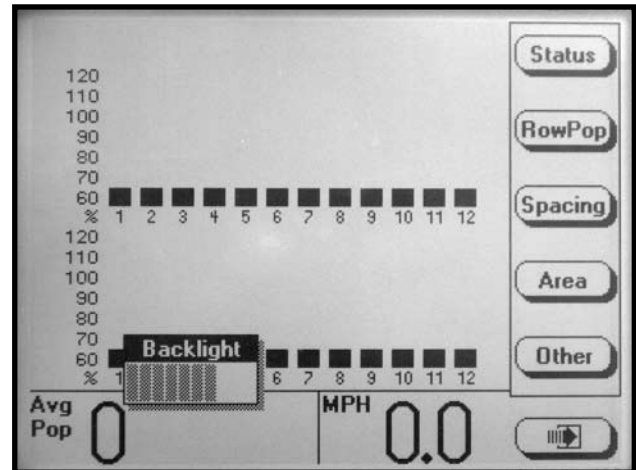

STEP 8 Use the LEFT and RIGHT arrows or turn the knob to adjust backlighting. The effect of the adjustment will be visible on the display.

STEP 9 Press the knob, ENTER or press the AV button a fourth time to save the volume, contrast and backlight settings. The backlight adjustment dialog box will disappear.

**PROGRAMMING INTERPLANT® CONDITION,
ROW SPACING AND UNITS (Metric Or English)**

STEP 1 To enter “Mode Selection” screen press the F6 key until “Mode Selection” screen appears.

D02140614

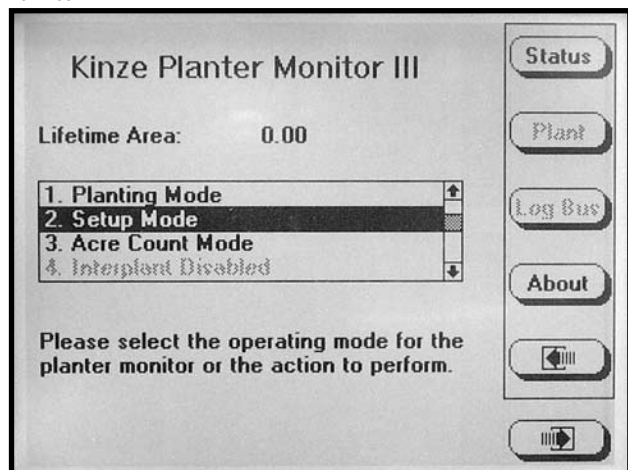

STEP 2 Select “Setup Mode” by turning the rotary encoder knob or using the UP or DOWN arrow keys. Press the knob or ENTER key to display the highlighted item.

STEP 3 Select “General Settings” by turning the knob or using the UP or DOWN arrow keys. Press the knob or the ENTER key to display the highlighted item.

D02140615

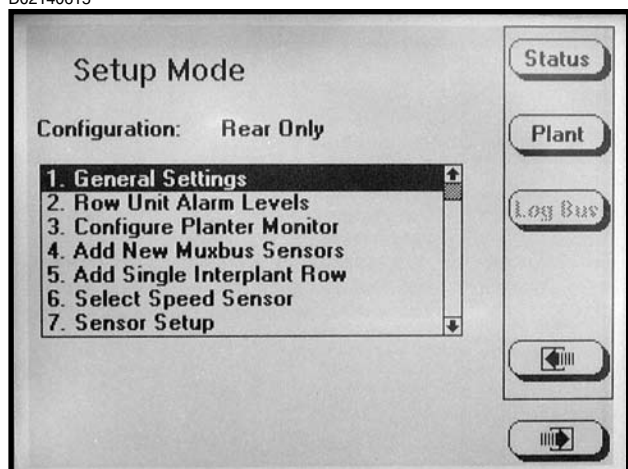

STEP 4 Press the knob or ENTER key and a drop down menu will appear. Select either “Enabled” (push row units are being used for planting) or “Disabled” (push row units are not being used for planting and no seed rate alarms will be generated for the front rows; no bargraphs are to be displayed for the front rows and the front rows do not contribute to the average population and spacing or acre counts). Use the knob or UP or DOWN arrow keys to make selection. Press the knob or ENTER key to select highlighted item. The black box will advance to “Row Spacing” field.

D02140616

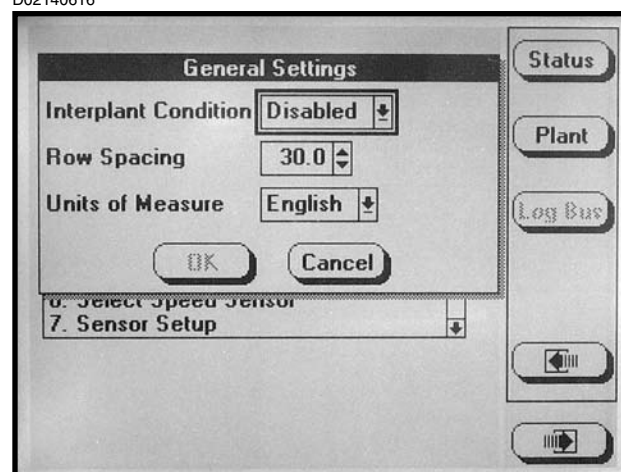

NOTE: When English is selected inches are displayed, if Metric is selected centimeters are displayed.

STEP 5 Press the knob or ENTER key to enter the correct value for “Row Spacing”. Turn the knob to increase or decrease the number. The UP arrow key is used to increase the value of the item by one and the DOWN arrow key is used to decrease the value of the field by one. The LEFT arrow key multiplies the value of the item by 10 and the RIGHT arrow key divides the value of the item by 10. When the correct number has been entered press the knob or ENTER key. The black box will advance to “Units of Measure” field.

NOTE: The narrowest row spacing the planter is equipped to plant should be entered for “Row Spacing”. Example: 12 Row 30" with Interplant, row spacing would be set to 15".

STEP 6 Select “Units Of Measure” field by pressing the knob or ENTER key and a drop down menu will appear. Select either “English” or “Metric” by turning the knob or using the UP or DOWN arrow keys. Press the knob or the ENTER key. The black box will advance to OK.

STEP 7 Press the knob or ENTER key, when correct values are entered.

STEP 8 To return to “Planting Mode” press the PLANT key.

PROGRAMMING ROW UNIT ALARM LEVELS

The Row Unit Alarm Levels allow the thresholds for the seed rate alarms to be set. The default is 50% or Average. If the average population drops below 50% for a given row a seed rate alarm will be generated for that row unit. The alarm threshold can be set to 70%, 50%, 10% or disabled for any row.

NOTE: When the alarm threshold is disabled for any row no seed rate alarm will be generated.

D02140623

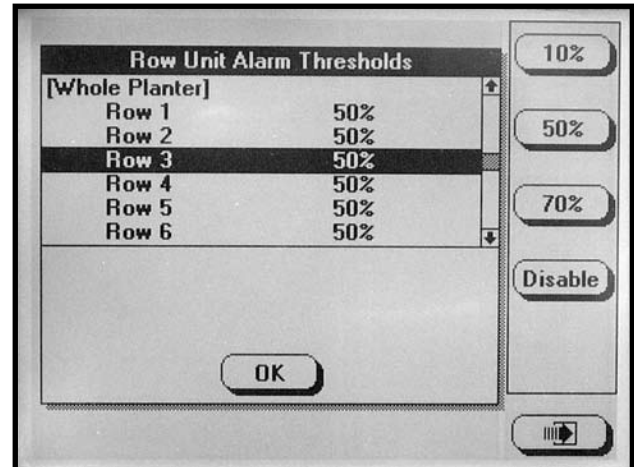

The alarm thresholds can be set for the whole planter, any planter section or individual rows.

NOTE: A section is determined by a set of rows driven by one or more shafts, designated to a single shaft sensor.

STEP 1 To enter “Mode Selection”, press F6 key until the “Mode Selection” screen appears.

STEP 2 Select “Setup Mode” by turning the rotary encoder knob or using the UP or DOWN arrow keys. Press the knob or ENTER key to display the highlighted item.

STEP 3 Select “Row Unit Alarm Levels” by turning the knob or using the UP or DOWN arrow keys. Press the knob or ENTER key to display the highlighted item.

STEP 4 To set alarm thresholds for whole planter, select “Whole Planter”. Press the key next to the desired threshold. When the desired threshold has been specified for all row units, press the knob or ENTER key.

To set alarm thresholds for all the rows in one section, select rear section or front section. Press the key next to the desired threshold. When the desired threshold has been specified for all row units, press the knob or ENTER key.

To set alarm thresholds for individual rows, select the desired row. Press the key next to the desired threshold. When the desired threshold has been specified for all row units, press the knob or ENTER key.

STEP 5 To return to “Planting Mode” press the PLANT key.

SPEED SENSOR CALIBRATION/PROGRAMMING

STEP 1 To enter the “Speed Sensor Calibration” mode, press F6 until the “Mode Selection” screen appears (If Applicable). Select “Setup Mode” and press the rotary encoder knob or ENTER key. Press F6 to advance to the “Speed Sensor Calibration” screen.

The Distance Pulse Count is used to record how many pulses are generated per mile/kilometer from the ground speed sensor. The monitor will display the current pulses per mile/kilometer using a 6 digit, no decimal place format.

D02140643

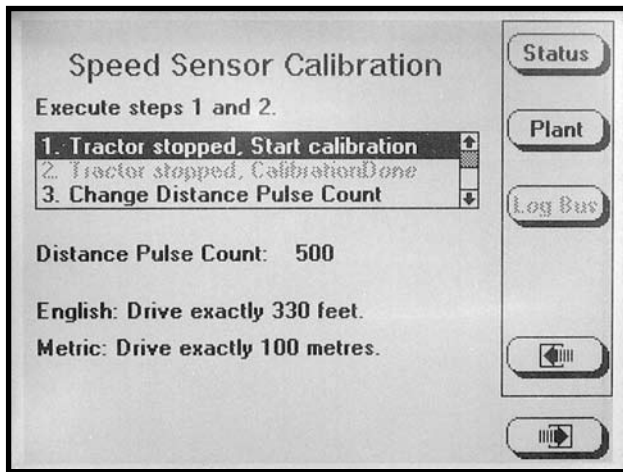

NOTE: A field calibration must be performed to establish the Distance Pulse Count number. Several factors can affect this value, such as wheel slip on the magnetic distance sensor. IT IS NOT UNCOMMON FOR THE SPEED ON THE MONITOR TO VARY SLIGHTLY FROM THE TRACTOR SPEEDOMETER. *Adjusting the Distance Pulse Count in the monitor to make the speed agree with the tractor can cause serious errors in acre/hectare and population/spacing readings. Do field checks to verify populations and seed spacing.*

- In field conditions, measure 330 feet or 100 meters, depending on the unit of measurement selected. Place a marker at the start point and end point.
- Pull the tractor up to the starting point.
- Select “Tractor stopped. Start calibration”.
- Press the rotary encoder knob or ENTER key to change the Distance Pulse Count on the display to 0.

NOTE: If the Distance Pulse Count number starts to count pulses with the tractor not moving, check radar distance sensor for vibration or other interference.

- Drive the tractor for 330 feet or 100 meters.
- The Monitor will count the number of pulses and display them.
- Stop the tractor at the end point.
- Select “Tractor stopped. Calibration Done”.
- Press the knob or ENTER key.

NOTE: Repeat the above steps multiple times. Record and average the values. Use this average for the Distance Pulse Count number constant.

STEP 2 Select “Change Distance Pulse Count” by turning the knob or using the DOWN arrow key. Press the knob or ENTER key.

D02200605

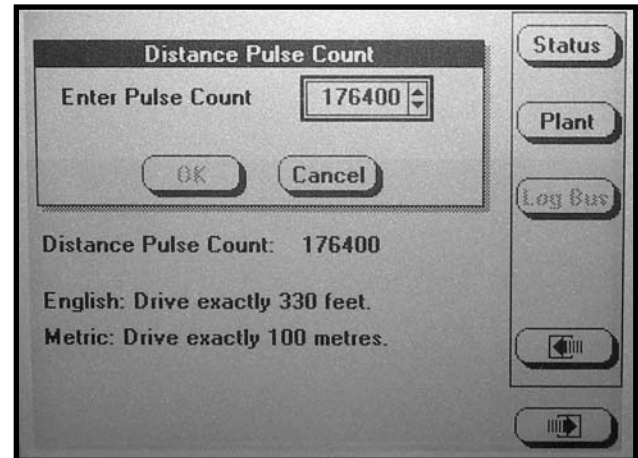

NOTE: The Distance Pulse Count will vary from the above example.

STEP 3 To return to “Planting Mode” press the PLANT key.

WHEN THE CORRECT DISTANCE PULSE COUNT IS KNOWN, CALIBRATION IS NOT NEEDED AND THE FOLLOWING STEPS MAY BE USED.

STEP 1 To enter the “Speed Sensor Calibration” screen, press F6 key until the “Mode Selection” screen appears (If Applicable). Select “Setup Mode” and press the rotary encoder knob or ENTER key. Press F6 key to advance to the “Speed Sensor Calibration” screen.

STEP 2 Select “Change Distance Pulse” field by turning the knob or using the UP or DOWN

D02200605

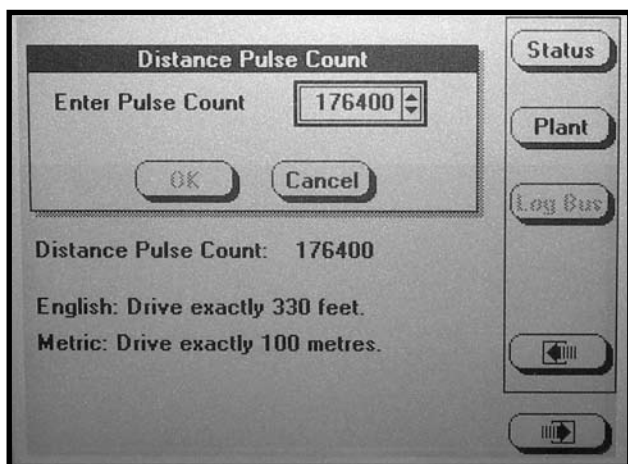

NOTE: The Distance Pulse Count will vary from the above example.

STEP 3 With the “Enter Pulse Count” field selected press the knob or ENTER key.

STEP 4 Change the Pulse Count to the desired value using the UP or DOWN arrow keys or turn the knob until the desired value is obtained. Press the knob or ENTER key.

NOTE: The LEFT arrow key multiplies the value of the item by 10 and the RIGHT arrow key divides the value of the item by 10.

STEP 5 Select OK by pressing the knob or ENTER key to save the new count. Select CANCEL to retain the old value of the Distance Pulse Count.

STEP 6 Press PLANT key to return to main planting screen.

REPROGRAMMING SPEED SENSOR

This setting must be specified when the monitor is first configured. It will be necessary to reprogram to use an alternate speed sensor.

NOTE: Speed sensors may not be changed while planting.

RADAR TO MAGNETIC DISTANCE SENSOR

STEP 1 Press the F6 key until the “Mode Selection” screen appears. Select “Setup Mode” by turning the rotary encoder knob or using the UP or DOWN arrow keys. Press the knob or ENTER key to display the highlighted item.

D02140614

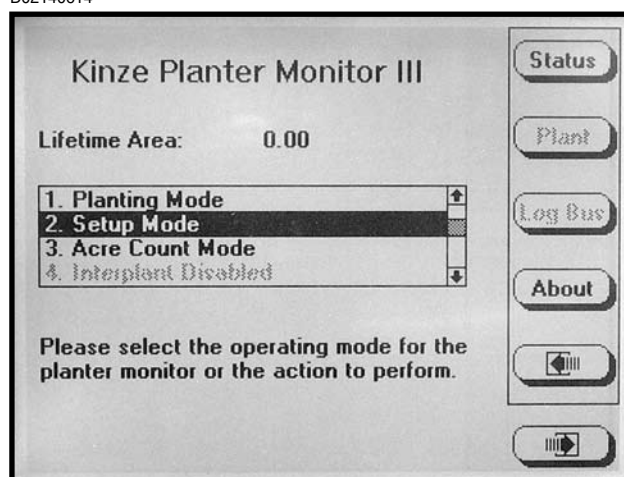

STEP 2 Turn the knob or use the UP or DOWN arrow keys to choose “Sensor Setup”. Press the knob or ENTER key to display the highlighted item.

D02140641

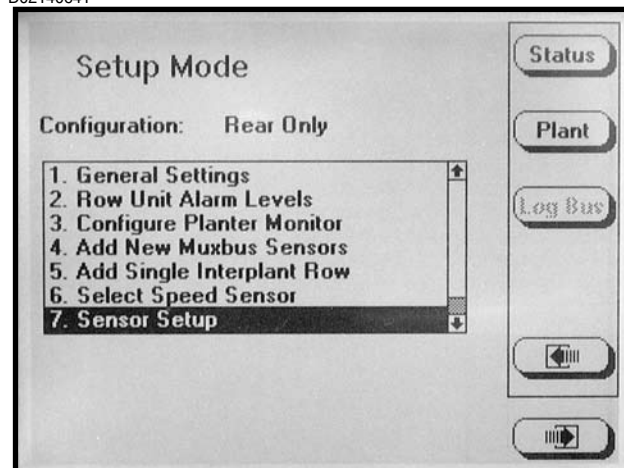

STEP 3 Turn the knob or use the UP or DOWN arrow keys to highlight “Mag Coil Pickup”. Plug in Magnetic Distance Sensor and press the INSTALL key. Press the knob or ENTER key to save information.

D05310609a

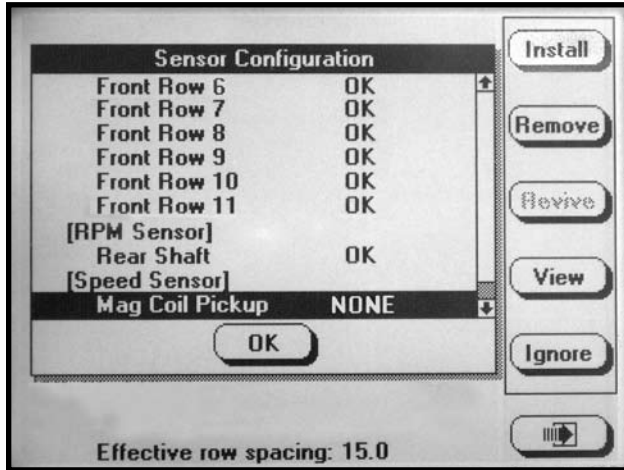

STEP 4 Turn the knob or use the UP or DOWN arrow keys to select “Select Speed Sensor” and press the knob or ENTER key. Press the knob or ENTER key to select the “Speed Sensor” field and a drop down menu will appear. Turn the knob or use the UP or DOWN arrow keys to select “Coil Pick-Up” and press the knob or ENTER key to make selection. The black box will advance to OK press the knob or ENTER key to save the information.

D02140639

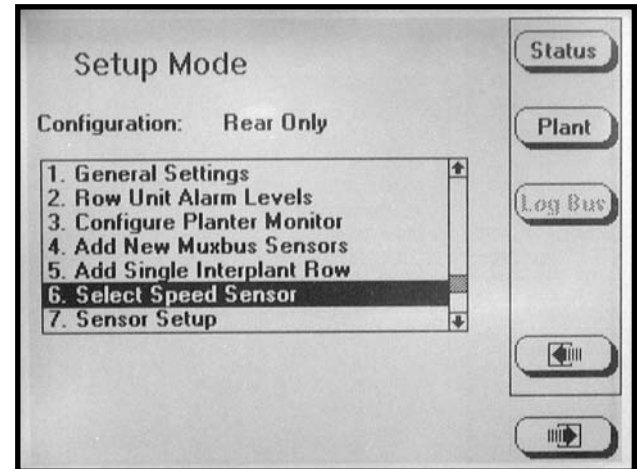

D05310609

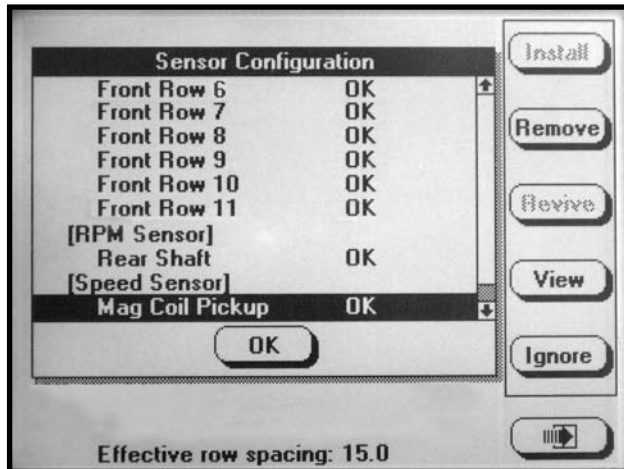

D02140639

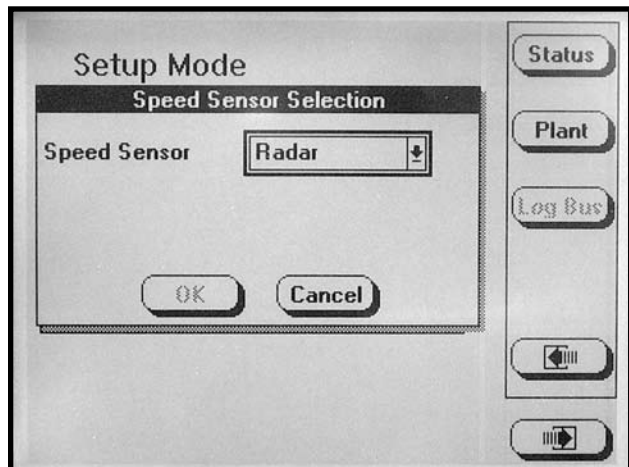

NOTE: To prevent the configuration from being changed select CANCEL, then press the rotary encoder knob, ENTER key or ESC key.

D06210601

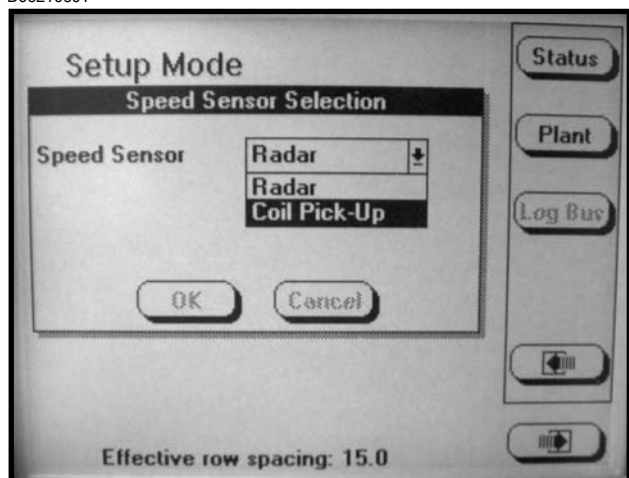

STEP 5 Unplug the radar from the tractor.

STEP 6 Press the PLANT key to return to main planting screen.

NOTE: When switching between speed sensors, verify the distance pulse count is correct for the chosen sensor. There will be significant distance pulse count variation between radar and coil pick-up sensors.

MAGNETIC DISTANCE SENSOR TO RADAR

STEP 1 Press the F6 key until the “Mode Selection” screen appears. Select “Setup Mode” by turning the rotary encoder knob or using the UP or DOWN arrow keys. Press the knob or ENTER key to display the highlighted item.

D02140614

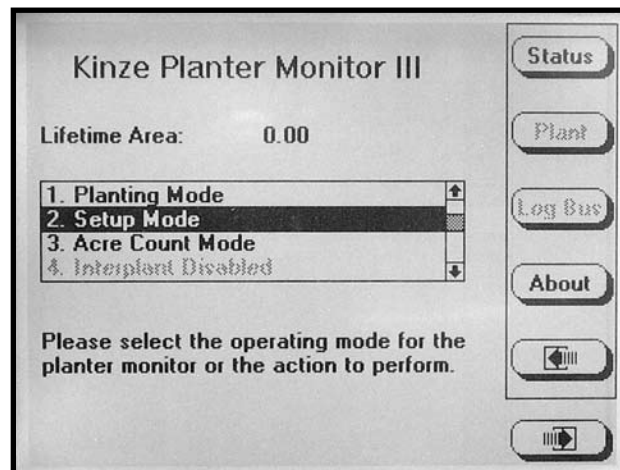

STEP 2 Turn the knob or use the UP or DOWN arrow keys to choose “Sensor Setup”. Turn the knob or use the UP or DOWN arrow keys to highlight “Mag Coil Pickup”. Press the REMOVE key, a note will appear for confirmation select as appropriate. Unplug Magnetic Distance Sensor and press the knob or ENTER key to save the information.

D02140641

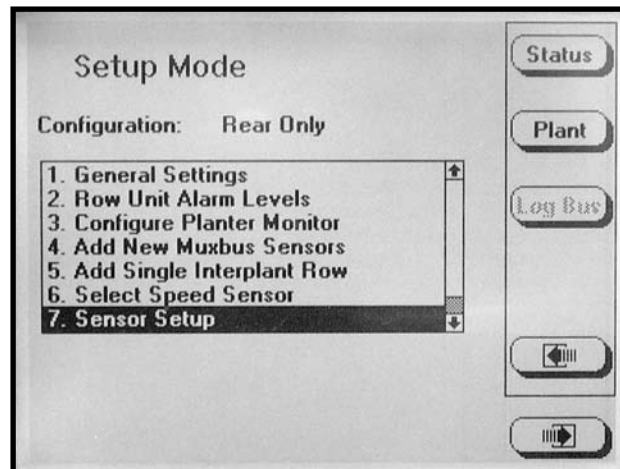

D05310609

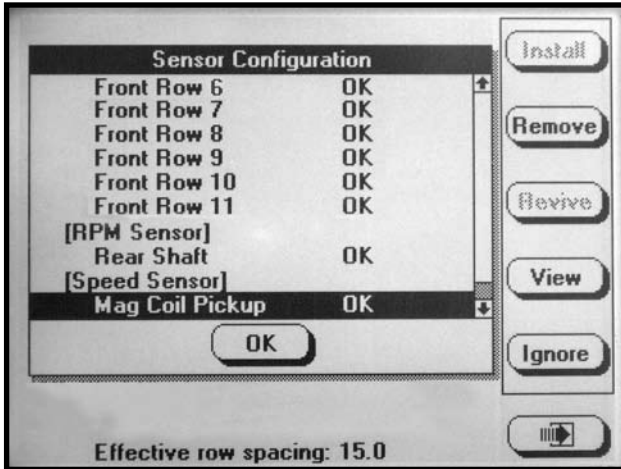

STEP 3 Turn the knob or use the UP or DOWN arrow keys to select “Select Speed Sensor” and press the knob or ENTER key. Press the knob or ENTER key to select the “Speed Sensor” field and a drop down menu will appear. Turn the knob or use the UP or DOWN arrow keys to select “Radar” and press the knob or ENTER key to make selection.

NOTE: To prevent the configuration from being changed select CANCEL, then press the knob, ENTER key or ESC key.

D02140640

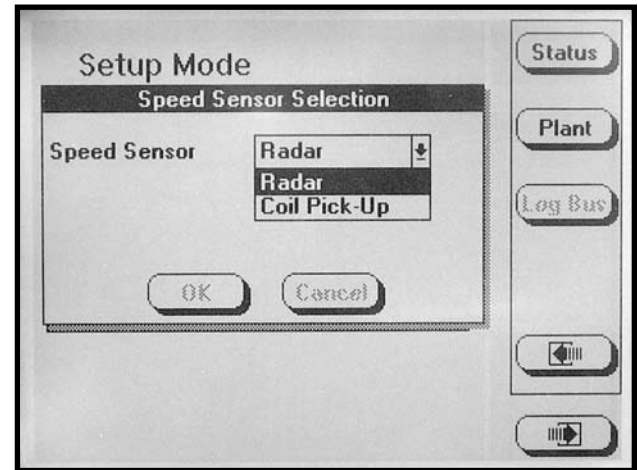

STEP 4 Plug in Radar and the black box will advance to OK. Press the knob or ENTER key to save the information.

STEP 5 Press the PLANT key to return to main planting screen.

NOTE: When switching between speed sensors, verify the distance pulse count is correct for the chosen sensor. There will be significant distance pulse count variation between radar and magnetic distance sensors.

D02140639

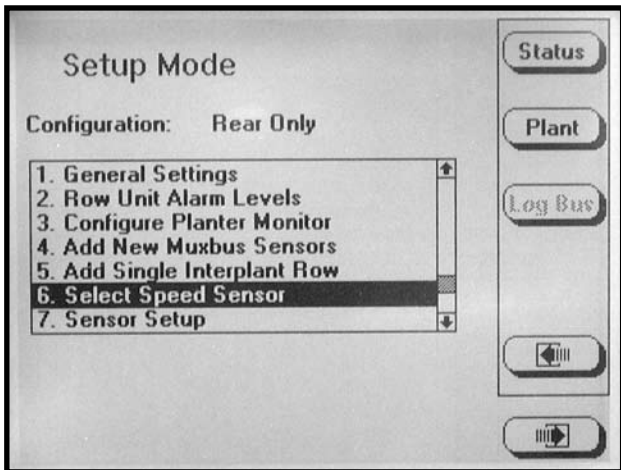

D02140639

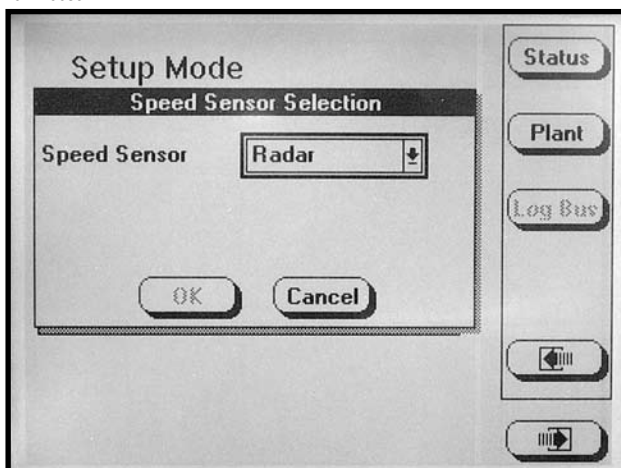

ADDING INTERPLANT® ROWS (If Rear Rows Have Previously Been Programmed)

STEP 1 Press the F6 key until “Mode Selection” screen appears.

STEP 2 Select “Setup Mode” by turning the rotary encoder knob or using the UP or DOWN arrow keys. Press the knob or ENTER key to display the highlighted item.

D02140614

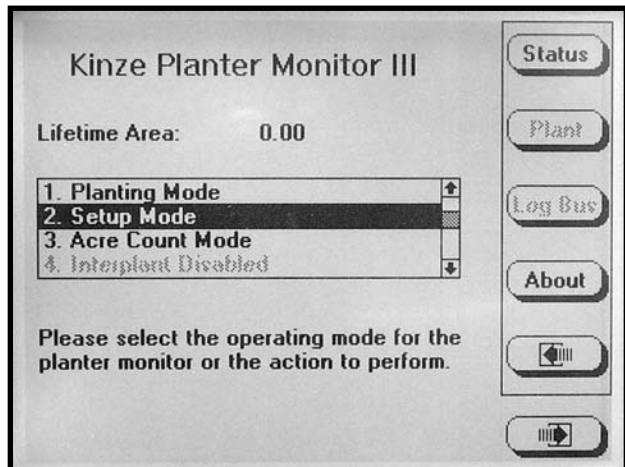

STEP 3 Select “Add New Muxbus Sensors” by turning the knob or using the UP and DOWN arrow keys. Press the knob or ENTER key to display the highlighted item.

D02140633

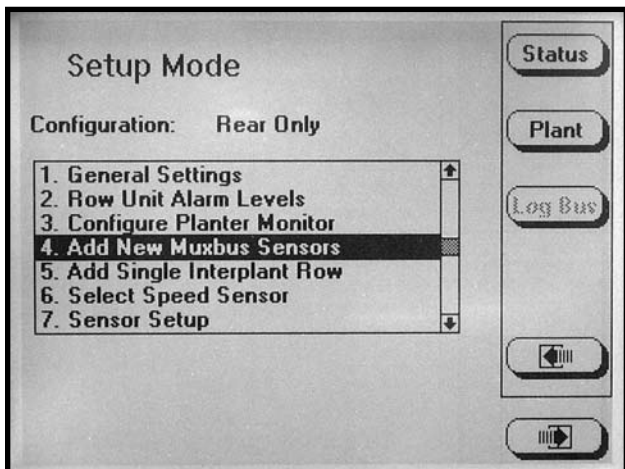

STEP 4 The note shown below will appear. Select OK by turning the knob or using the UP or DOWN arrow keys. Press the knob or ENTER key to make the selection.

D03010601

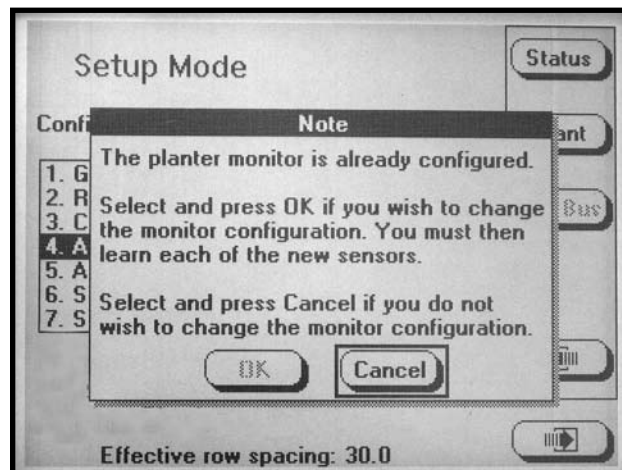

STEP 5 Turn the knob or use the UP or DOWN arrow keys to select the “Front Row Units” field and press the knob or ENTER key to highlight the field. Turn the knob or use the UP or DOWN arrow keys to obtain the desired number of rows. When the correct value has been entered press the knob or ENTER key. The black box will advance to the OK key. Press the knob or ENTER key to save the information.

NOTE: To prevent the configuration from being changed select CANCEL, then press the knob, ENTER key or ESC key.

D02220674

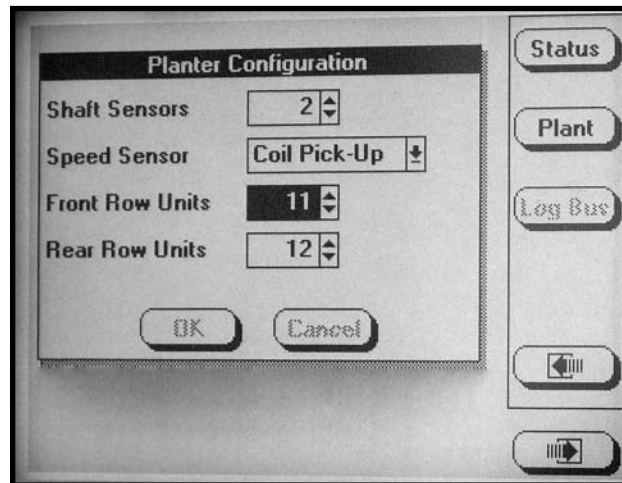

NOTE: Attempting to add rear rows while adding new muxbus sensors will cause the following note to appear.

D02220675

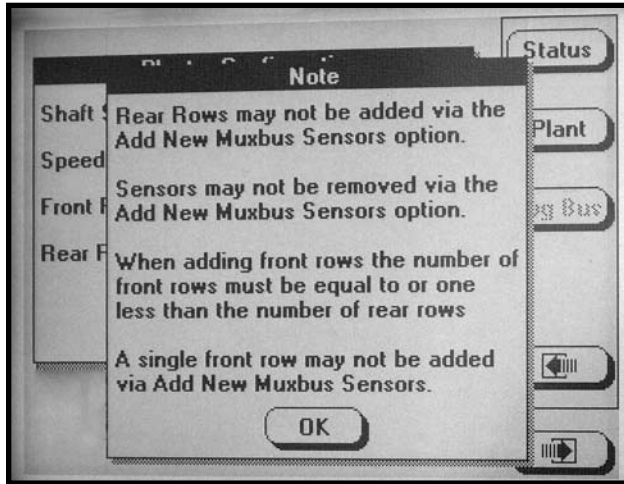

STEP 6 The note shown below will appear. Select OK by turning the knob or using the UP or DOWN arrow keys. Press the knob or ENTER key to make the selection.

D03010603

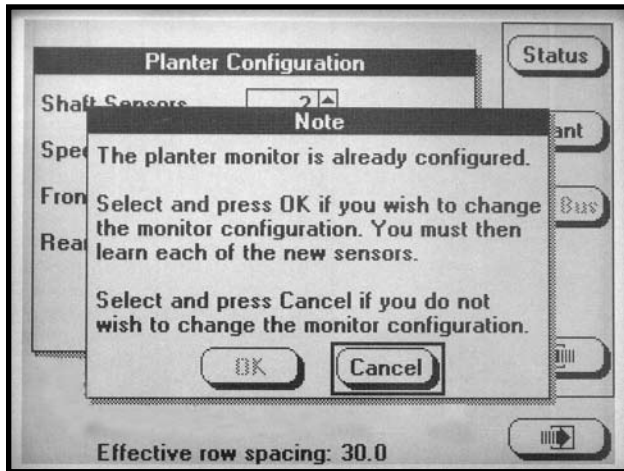

NOTE: To prevent the configuration from being changed select CANCEL, then press the knob, ENTER key or ESC key.

STEP 7 The sensor configuration screen will appear. With [Auto Detect] highlighted select INSTALL. Begin to install sensors from left to right.

D02230604a

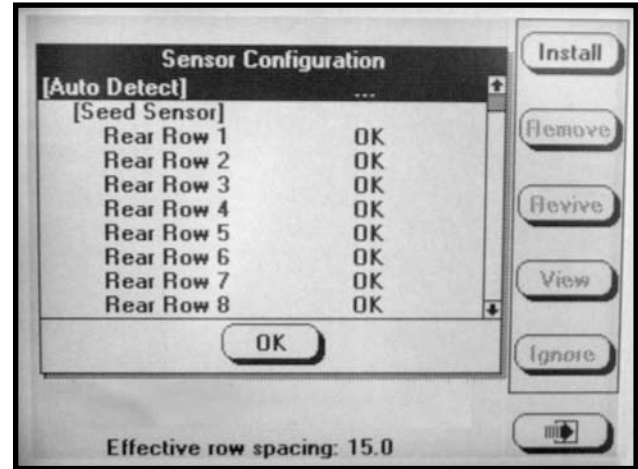

D02220672

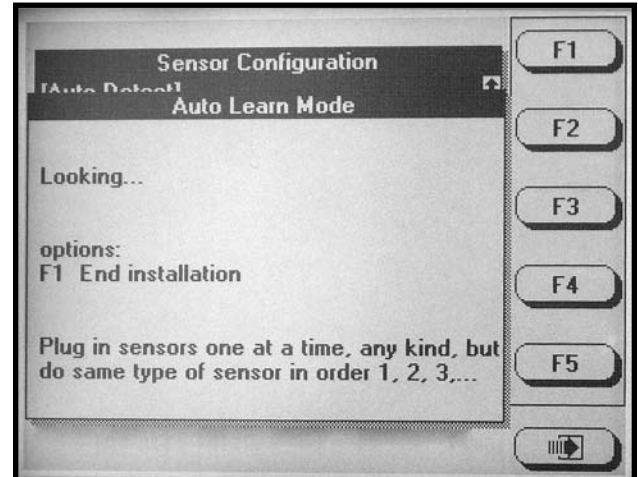

STEP 8 When all sensors are learned select F1 to end installation. Scroll down to verify the front rows are learned. Select OK by pressing the knob or ENTER key.

NOTE: "OK" will appear next to each sensor if no errors are detected.

STEP 9 Select “General Settings”, by turning the knob or using the UP or DOWN arrow keys. Press the knob or ENTER key to make the selection.

D02140615

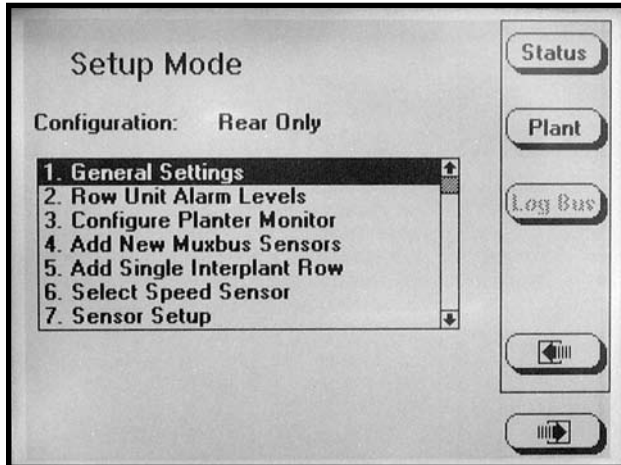

STEP 10 Select the “Row Spacing” field by turning the knob or using the UP or DOWN arrow keys. Press the knob or ENTER key to highlight field. Adjust the row spacing to Interplant spacing by turning the knob or using the UP or DOWN arrow keys. Press the knob or ENTER key to enter the value. Then turn the knob or use the UP or DOWN arrow keys to advance to OK. Press the knob or enter key to save row spacing.

NOTE: To prevent the configuration from being changed select CANCEL, then press the knob, ENTER key or ESC key.

STEP 11 To return to “Planting Mode” press the PLANT key.

ADDING EVEN-ROW PACKAGE (If Front Rows Have Previously Been Programmed)

STEP 1 Press the F6 key until “Mode Selection” screen appears.

STEP 2 Select “Setup Mode” by turning the rotary encoder knob or using the UP or DOWN arrow keys. Press the knob or ENTER key to display the highlighted item.

D02140614

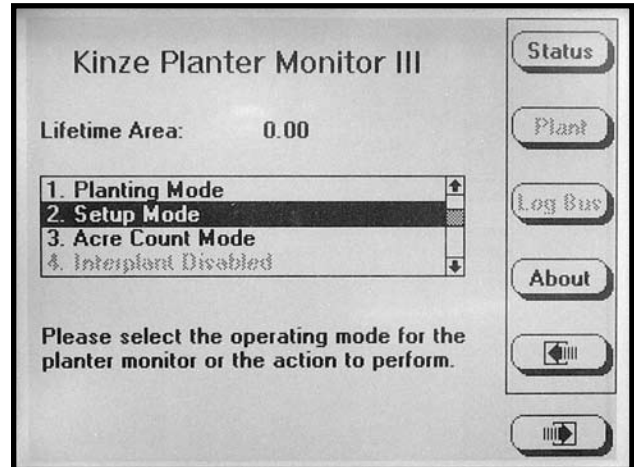

STEP 3 Select “Add Single Interplant Row” by turning the knob or using the UP and DOWN arrow keys. Press the knob or the ENTER key to display the highlighted item.

D022206200

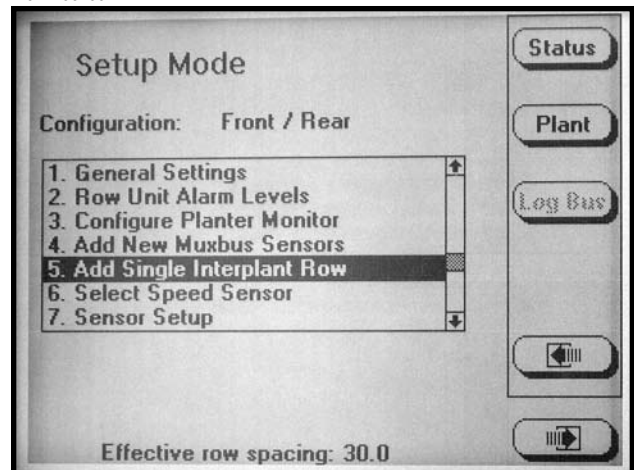

STEP 4 To confirm the following note turn the knob or use the UP or DOWN arrow keys to select OK and then press the knob or ENTER key to confirm. If the single Interplant row is not to be added select the CANCEL key and press the knob or ENTER key to cancel or press the ESC key.

D022206201

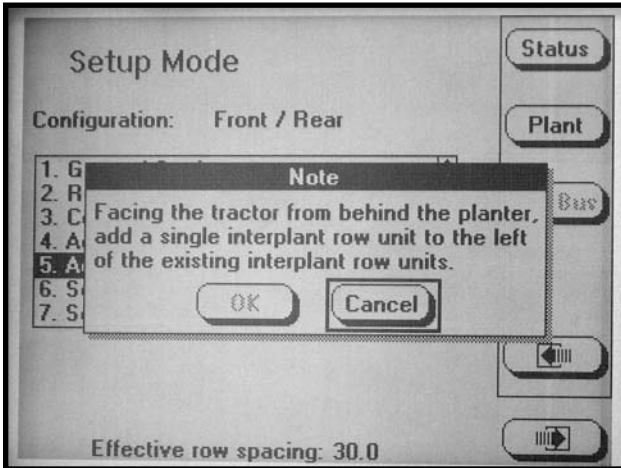

STEP 5 To "Add Single Interplant Row" the following screen will appear.

If the single Interplant row is to be added turn the knob or use the UP or DOWN arrow keys to select OK and then press the knob or ENTER key to add the Interplant row. If the single Interplant row is not to be added select the CANCEL key and press the knob or ENTER key to cancel or press the ESC key.

D022206202

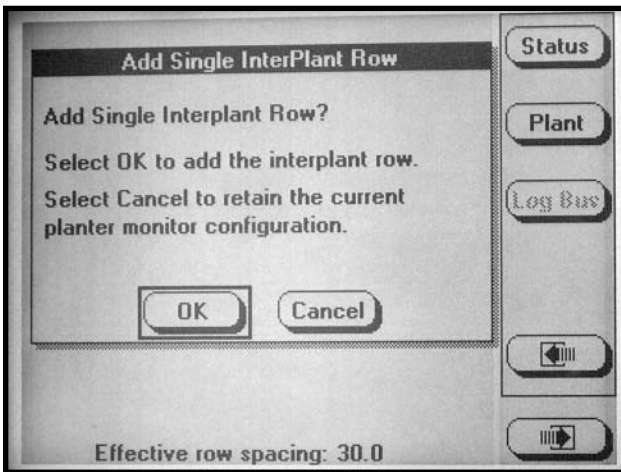

STEP 6 The "Sensor Configuration" screen will appear. Plug in the new sensor then scroll down to highlight "Front Row 1" by turning the knob or using the UP or DOWN arrow keys. Select INSTALL to learn the new sensor. Press the knob or ENTER key to return to setup mode.

D02220670

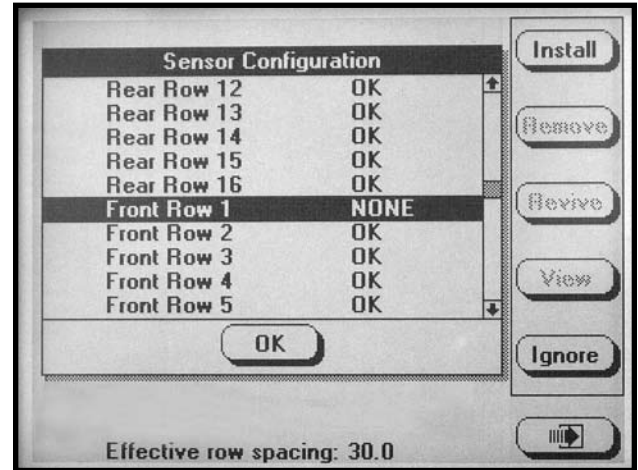

STEP 7 To return to "Planting Mode" press the PLANT key.

ENABLING/DISABLING INTERPLANT® ROWS

To Enable or Disable Interplant (a) press the F6 key until the “Mode Selection” screen appears, (b) turn the rotary encoder knob or use the UP or DOWN arrow keys to highlight “Disable/Enable Interplant”, (c) press the knob or ENTER key to “Disable” or “Enable” Interplant. To verify selection, the row spacing is displayed on the bottom of the screen.

D03010605a

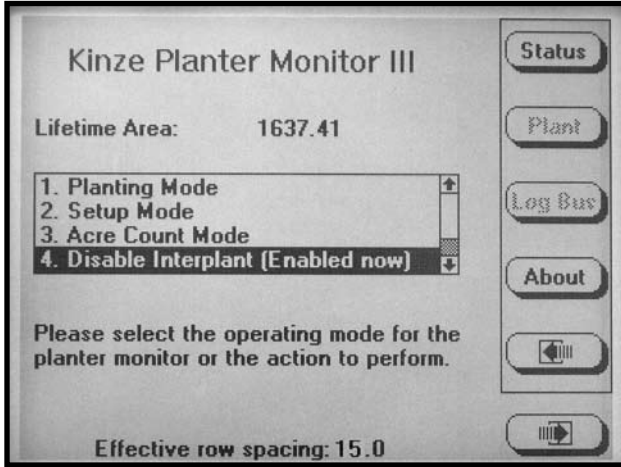

Either select the “Planting Mode” by turning the knob or using the UP arrow key and press the knob or ENTER key or press F6 to return to the “Planting Mode”.

D02240602

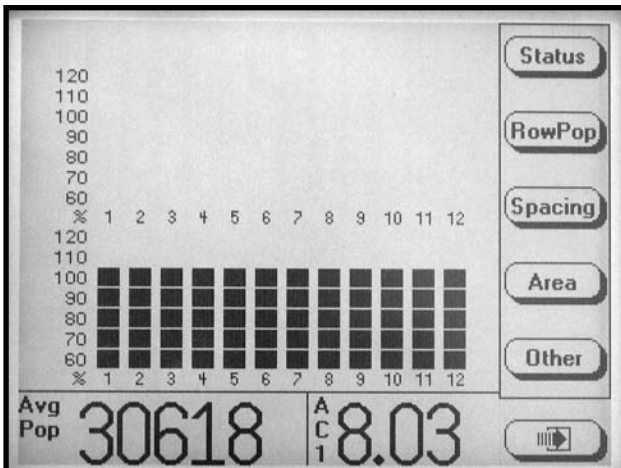

ROW POPULATION

- Press the ROW POP key to display row population. Average planter population will be shown in the lower L.H. corner of the display.

D05310614

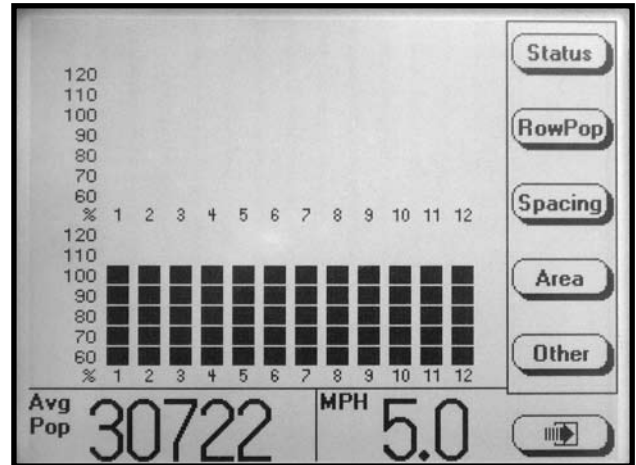

- Press the SCAN key and the monitor will scan through each row in ascending order displaying the average seed population for each row. After all rows have been scanned the average population is displayed and scan function will continue with the first rear row.

D02240604

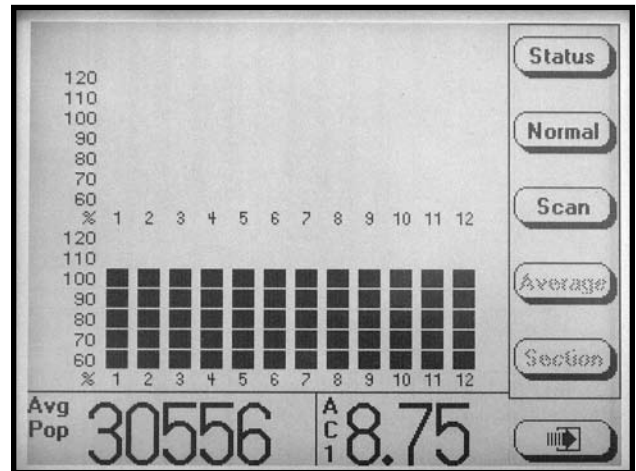

- Press the FREEZE key to stop scanning, the left display item will be frozen on a particular row. “Frzn” appears in the lower L.H. corner to indicate the display is frozen. To resume scan press the SCAN key.

EXAMPLE: When average row population is shown, R3 indicates rear row 3, F2 indicates front row 2, etc.

D05310615

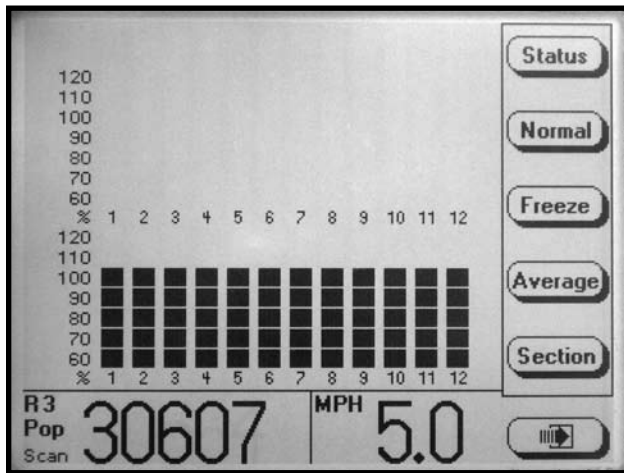

- When either Scan or Frzn is displayed in the L.H. corner the SECTION and arrow keys function as follows: (a) SECTION or RIGHT arrow key advances to the first row of the next section; (b) SECTION or LEFT arrow key selects the first row of the previous section, wrapping around to the first row of the last section when moving past the first section; (c) UP arrow key moves forward to the next row of the planter, wrapping around to the first row when moving past the last row; (d) DOWN arrow key moves backward to the previous row of the planter, wrapping around to the last row of the planter when moving past the first row.
- Press the AVERAGE key to display the average population in the bottom L.H. corner.
- Press the NORMAL key to display the normal screen for planting mode.

NOTE: If the rows are being scanned and the AVERAGE key is selected the scan function will stop.

ROW SPACING

- Press the SPACING key to display seed spacing keys. Seed spacing will appear in the bottom L.H. corner of the display.

D02240602

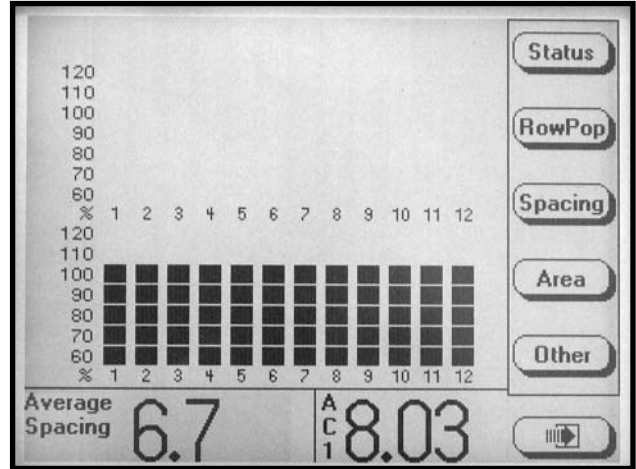

D02240605

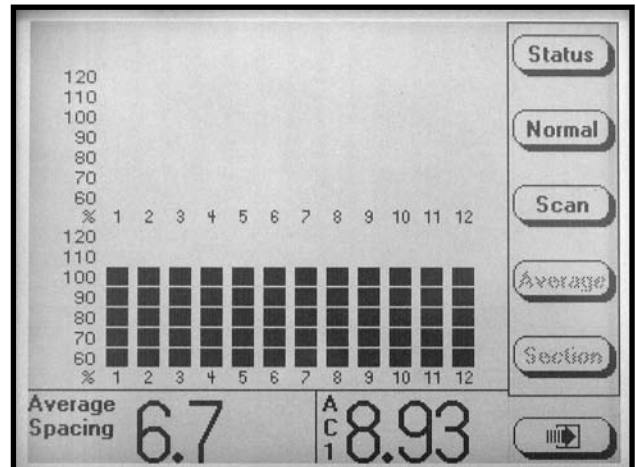

- Press the SCAN key and the monitor will scan through each row in ascending order displaying the average seed spacing for each row. Scan appears in the L.H. corner to indicate the display is scanning. After all rows have been scanned the average population is displayed and scanning will continue with the first rear row.
- Press the FREEZE key to stop scanning and the left display item will be frozen on a particular row. “Frzn” appears to indicate the display is frozen. To resume scan press the SCAN key.

- When either "Scan" or "Frzn" is displayed in the left display item the SECTION and arrow keys function as follows: (a) SECTION and RIGHT arrow key advances to the first row of the next section; (b) LEFT arrow key selects the first row of the previous section, wrapping around to the first row of the last section when moving past the first section; (c) UP arrow key moves forward to the next row of the planter, wrapping around to the first row when moving past the last row; (d) DOWN arrow key moves backward to the previous row of the planter, wrapping around to the last row of the planter when moving past the first row.

- Press the AVERAGE key to display the average seed spacing in the bottom L.H. corner.
- Press the NORMAL key to display the main planting mode.

NOTE: If the rows are being scanned and the AVERAGE key is selected the scan function will stop.

SPEED/SHAFT ROTATION

- Press the OTHER key to display items available to display in the bottom R.H. corner.

- Press the SHAFT key to view the average meter shaft RPM. The value will appear in the bottom R.H. corner of the display.

NOTE: Applicable to planters with shaft rotation sensors installed.

D02240607

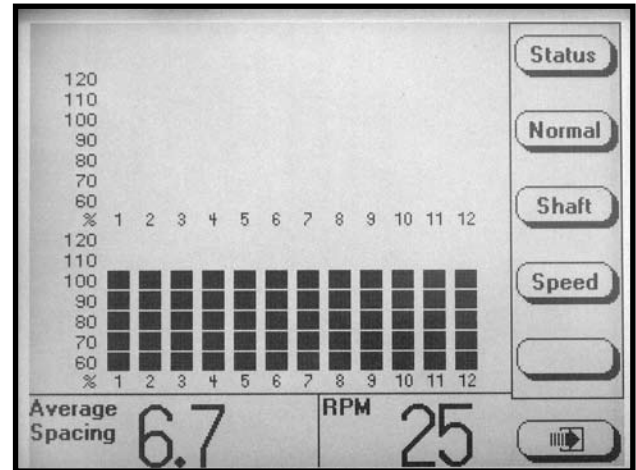

- Press the SPEED key to view the ground speed. The value will appear in the bottom R.H. corner of the display.

D02240602

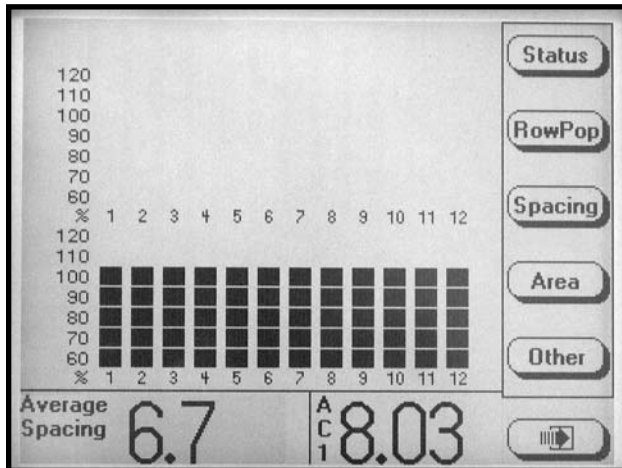

D02240608

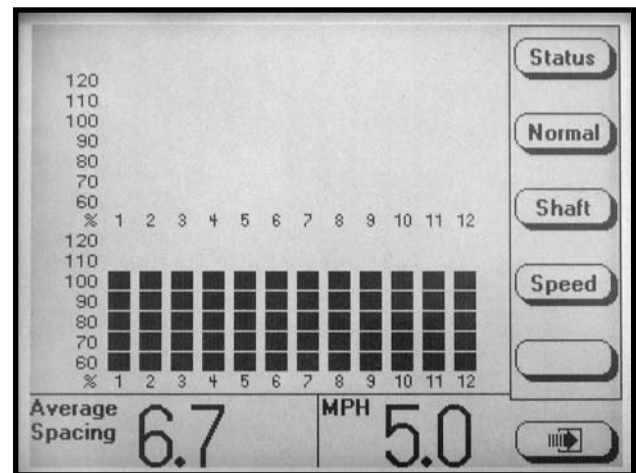

NOTE: The appropriate units of measure will be displayed (English or Metric).

- Press NORMAL to bring back the standard key labels.

D02240606

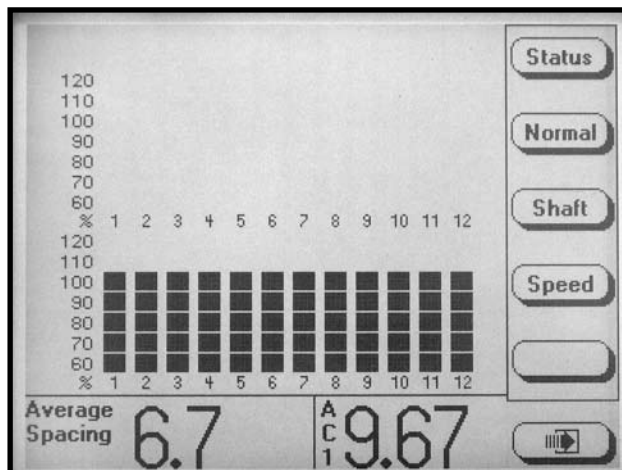

WARNINGS AND ALARMS

- Seed Rate Alarm** - A seed rate alarm is activated whenever the row average seed population drops below the threshold set for that row.

The corresponding row on the bargraph starts flashing and the monitor emits a series of beeps that persist until the alarm is clear or the ACK button is pressed. "Seed Rate Alarm" appears in the upper left corner of the screen. The bargraph for the row drops down based on the threshold set for the alarm.

EXAMPLE: If the threshold is 70% the lower two bargraph segments are shown. If the threshold is 50% or 10% the lowest bargraph segment is shown.

The status message associated with an alarm contains more information about the alarm. To view the "Status Message" for a seed rate alarm, press the STATUS key.

If the sensor is detecting no seed flow it will display which row is not functioning. The alarm may be indicating a mechanical problem that is reducing the seed flow or an electrical problem causing the seed counts to be incorrect.

NOTE: The only way to remove an alarm is to find and correct the problem and correct it. Alarms are not reported for rows that seed rate alarm thresholds have been disabled.

NOTE: The percentage shown in the alarm message is the percentage at the time the alarm occurred.

- Section Not Planting** - When the monitor detects an entire section not planting, the monitor will emit three beeps to alert the user. The bargraph for the affected section flashes and is reduced to the lowest segment. An alarm message is added to the list of "Status Messages". Press the STATUS key to view the alarm message.

- Seed Counting Sensors Not Communicating With Monitor** - When the monitor detects a communication error between the sensor and the monitor, the monitor will emit two beeps to alert the user. Try to reestablish communication with sensor(s) by pressing F2. If the monitor is unable to establish communication there may be (a) a faulty sensor, (b) a poor electrical connection or (c) a cut or pinched wire harness.

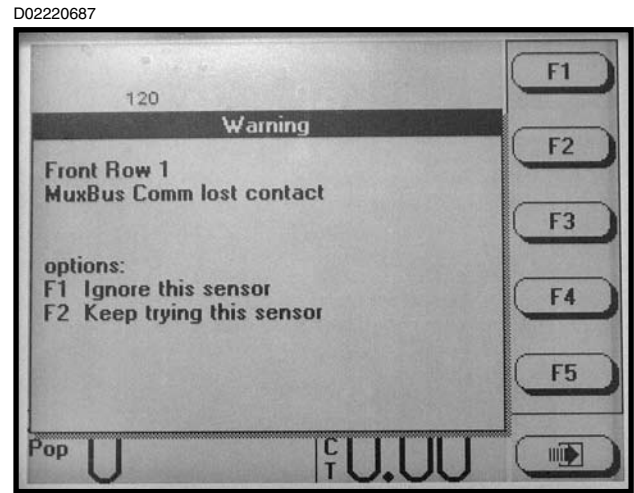

If multiple sensors have lost contact, the message will indicate which sensors have lost contact.

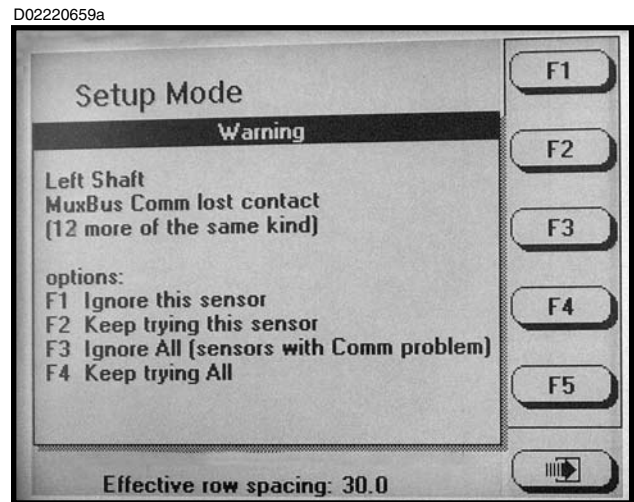

NOTE: When it is known that a sensor or a group of sensors are faulty, F1 or F3 should be pressed. The monitor will no longer try to communicate with the sensor(s). In the planting mode the corresponding bargraphs will be grayed out in the main screen.

D02220691

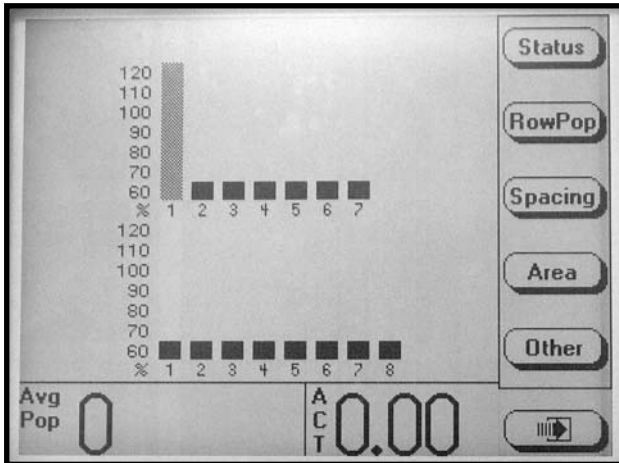

NOTE: If the sensors are not faulty, F2 or F4 should be pressed and the message shown below will appear when the STATUS key is pressed.

D02220685

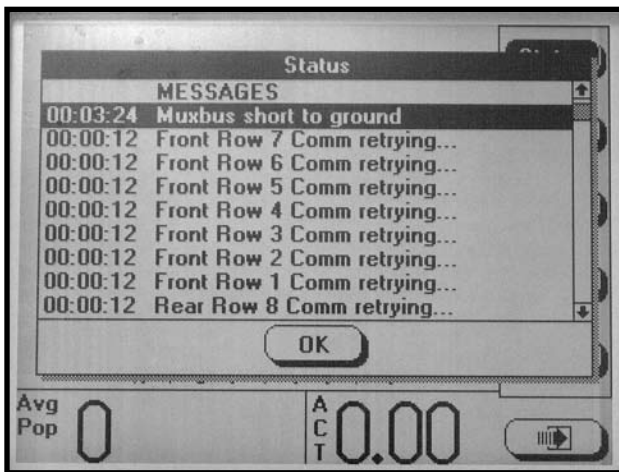

NOTE: If a sensor has been ignored, the sensor configuration screen will display as shown below.

D02220692

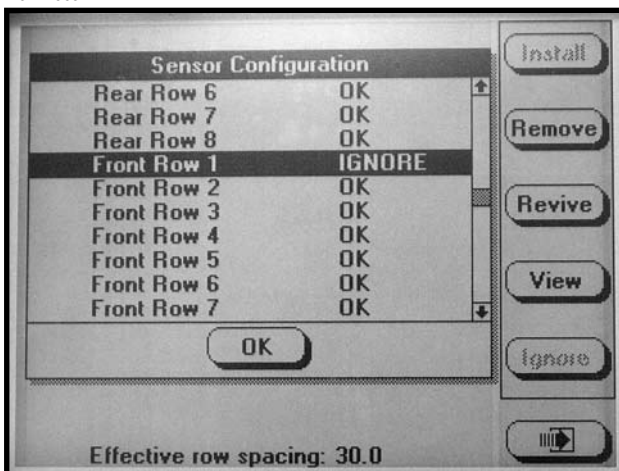

- Seed Counting Sensors Too Dirty Warning** - When powering on the KPM III, each of the seed sensors will do a self check. If a seed tube is too dirty, the message “Clean Or Replace Sensor As Necessary” will be displayed and the bargraph for that row will flash. The LED on the seed tube sensor will not flash. The sensor will not function until the problem is corrected.

NOTE: After the alarms have been acknowledged and if the alarm condition is still present, the LCD screen will continue to display the alarm condition.

- Wire Shorts** - When a wire is shorted any one of the messages shown below will appear, stating which wires are shorted. The short must be located and fixed to continue planting. Cycle the power on the monitor to clear the alarm.

D02220683

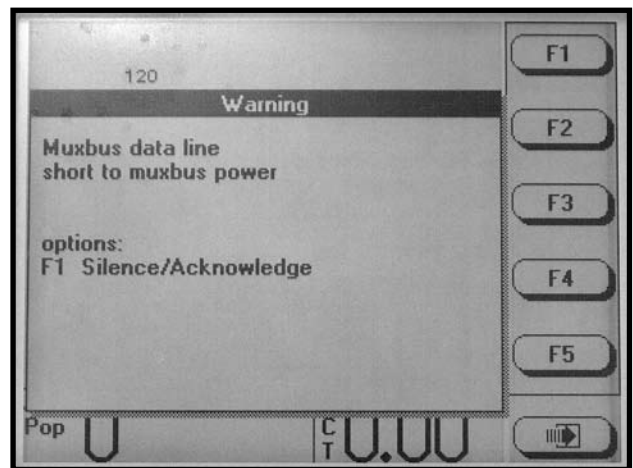

D02220684

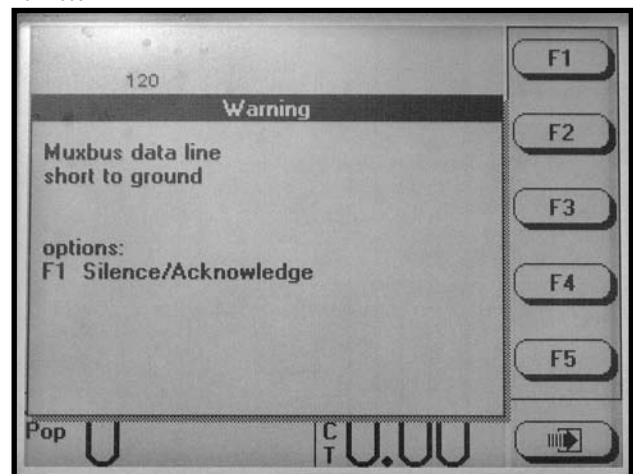

FIELD OPERATION

Press the ON/OFF key to turn the monitor ON.

If the monitor has been configured, it will enter the normal planting mode and attempt to communicate with the seed sensors.

D02200606

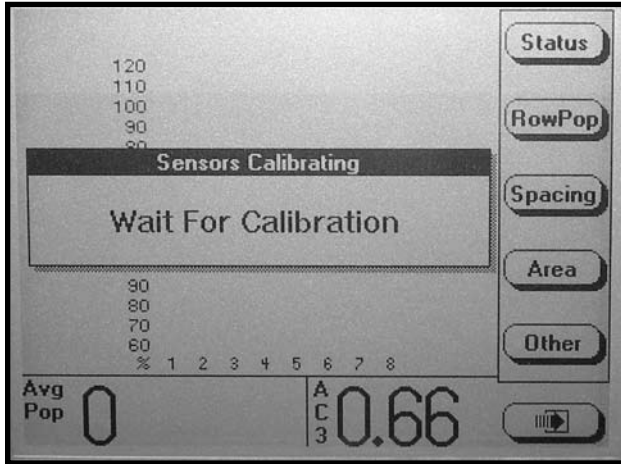

NOTE: Do not attempt planting before the “Wait For Calibration” message disappears. If planter is moving while sensors are calibrating alarms will be generated.

NOTE: If the monitor can communicate with the sensors the normal planting mode screen will be displayed.

D0220689a

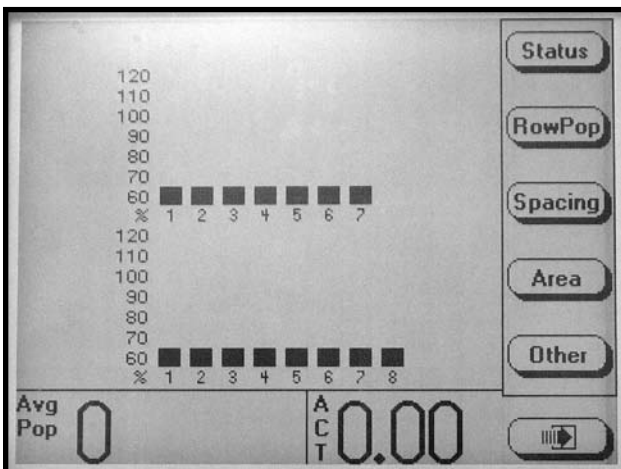

If the monitor does not detect any sensors the message shown below will appear.

D02200627

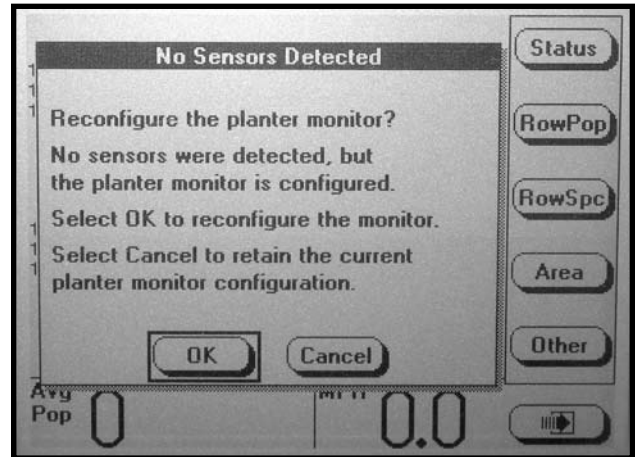

NOTE: Selecting OK will reconfigure the monitor requiring all sensors to be re-learned. Selecting CANCEL will maintain the current configuration and the monitor will continue trying to communicate with the sensors.

AREA MANAGEMENT

There are 10 area counters: Total Area, Field Area and area counters 1 through 8. The Total Area is always active but may be cleared. If it is cleared, the Field Area is also cleared. Field Area and Area Counters 1 through 8 may be cleared independent of each other. They may also be started or stopped at anytime. In addition, there is a Lifetime Area Counter (located on the Mode Selection Screen) which can not be disabled or cleared by the user.

To enter the "Area Management" screen, press the F6 key until the "Area Management" screen appears.

D02210626a

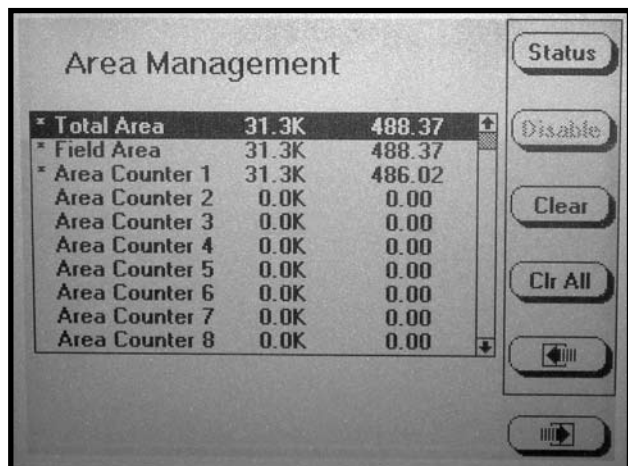

NOTE: Total area counter can never be disabled, but can be reset to zero (cleared).

- The asterisk next to the name of the area counter indicates the area counter is enabled and accumulating area.

EXAMPLE: In the photo shown above, 31.3K indicates the average seed population for the accumulated area is 31,300 seeds per unit area (acre/hectare). This number has been rounded off. The actual seed population ranges anywhere from 30,500 to 31,499 per unit area. The last column of numbers is the area accumulated (acre/hectare).

- Turn the knob or use the UP or DOWN arrow keys to highlight the desired "Area Counter".
- Press the ENABLE or DISABLE key.

NOTE: Up to four area counters can be enabled at one time (two area counters in addition to Total Area and Field Area). If four area counters are already enabled, disable one active area counter in order to enable a new area counter. To disable or enable area counters see next column.

NOTE: When a key is dimmed it does not perform any operation on the highlighted area counter.

ENABLE AREA COUNTER

Each of the "Disabled Area Counters" may be enabled up to a total of four "Area Counters". To Enable a Disabled "Area Counter": (a) highlight the desired "Area Counter" by turning the rotary encoder knob or using the UP or DOWN arrow keys; (b) press the ENABLE key or press the knob or ENTER key and an asterisk will appear next to the "Area Counter". The Enabled "Area Counter" starts accumulating area.

DISABLE AREA COUNTER

Each of the Enabled Area Counters may be disabled, with the exception of the Total Area Counter. To disable an enabled area counter: (a) highlight that "Area Counter"; (b) press the DISABLE key or press the rotary encoder knob or ENTER key and the asterisk next to the "Area Counter" will disappear. The "Disabled Area Counter" will no longer accumulate area.

NOTE: Attempts to disable an Area Counter that is currently being displayed while planting will cause the following alarm.

D02210627a

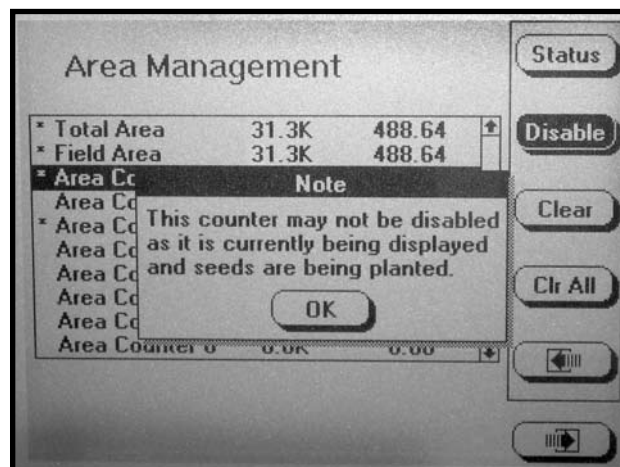

D02210626a

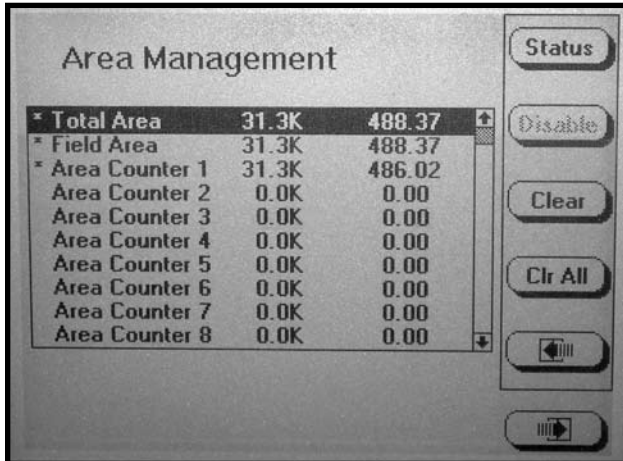

NOTE: If the total area is highlighted and the CLEAR key is pressed the following request for confirmation will appear.

D02200612

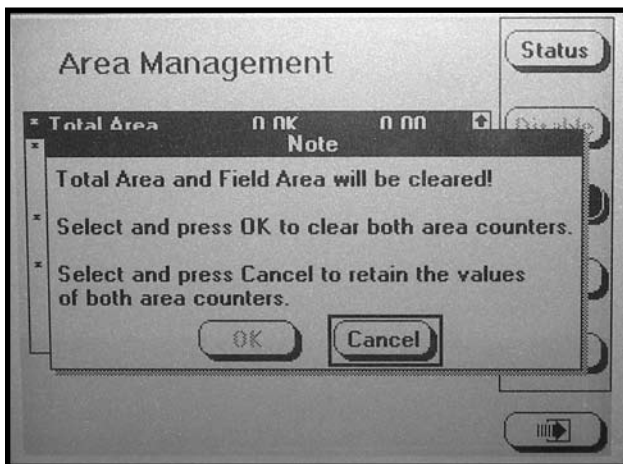

CLEAR AREA COUNTER

Total Area, Field Area and Area Counters 1 through 8 can be cleared, whether they are Enabled or Disabled. Clearing the “Total Area” counter forces the “Field Area” counter to also be cleared. Clearing any other “Area Counter” including the “Field Area” counter clears only that counter.

NOTE: Lifetime Area Counter can never be cleared or disabled.

To clear an Area Counter: (a) highlight the desired area counter, by turning the rotary encoder knob or using the UP or DOWN arrow keys, (b) press the CLEAR key, (c) the request for confirmation shown below will appear, (d) turn the knob or use the UP or DOWN arrow keys to select OK or CANCEL, (e) press the knob or ENTER key to make selection.

To Clear All Area Counters except the “Total Area Counter”: (a) select the CLR ALL key; (b) a request for confirmation will appear; (c) turn the knob or use the UP or DOWN arrow keys to select either OK or CANCEL; (d) press the knob or ENTER key to confirm selection.

D02210628

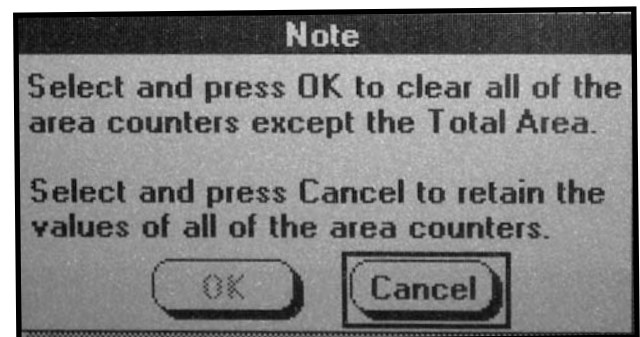

AREA COUNTERS

STEP 1 On the main planting screen press the AREA key.

D02240602

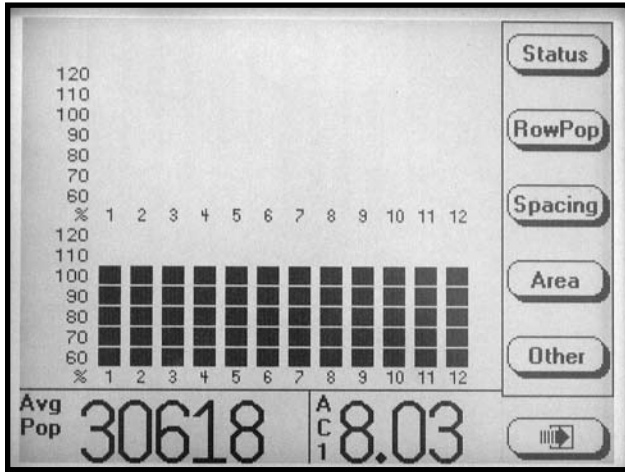

STEP 2 Press the SELECT key to display the list of the Enabled Area Counters.

D02240603

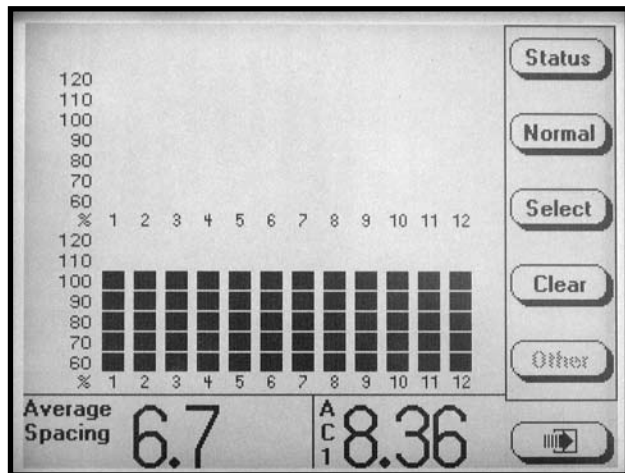

STEP 3 To select the desired active "Area Counter" turn the knob or use the UP or DOWN arrows to highlight the desired "Area Counter".

D02240609

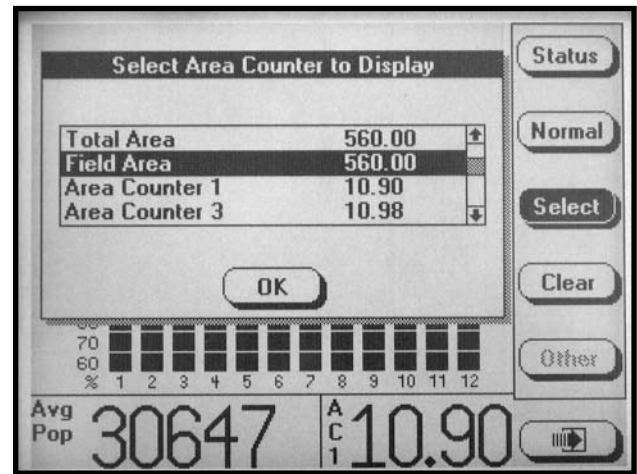

STEP 4 Press the knob or ENTER key to select OK. The planting screen will then be displayed. Press NORMAL to display main planting screen.

D02240610

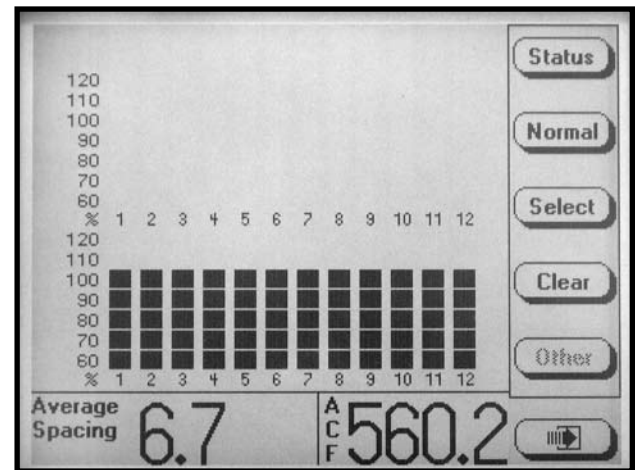

NOTE: The abbreviation for the selected area counter numerical value will appear in the bottom R.H. corner of the screen. In the above photo "ACF" represents "Area Counter Field"

CLEARING FIELD AREA

To reset the counter, display the main planting screen by pressing the F6 key until it appears. Press the AREA key then select the CLEAR key, a dialog box will appear requesting confirmation to clear. Select OK or CANCEL key by turning the rotary encoder knob or using the UP or DOWN arrow keys. Press the knob or ENTER key to verify the selection.

D02210625

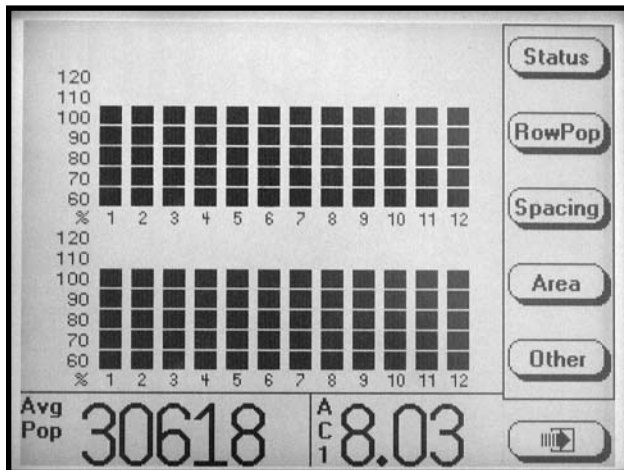

D02210625

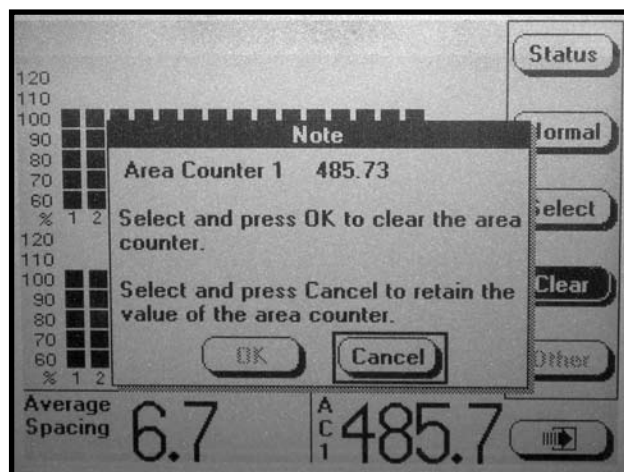

NOTE: Only the displayed Area Counter can be disabled.

ACRE COUNT MODE

When a tractor is equipped with a radar distance sensor, accumulating area without a planter attached is possible. Two routes are provided to enter acre count mode: (a) Installation of an Acre Count Switch Kit or (b) entry into Acre Count Mode.

Acre Count Switch Kit

STEP 1 With the monitor OFF, attach an Acre Count Switch Kit to the Muxbus connector and then turn monitor ON and advance to STEP 2.

Acre Count Mode

STEP 1 Press the F6 key until the “Mode Selection” screen appears. Turn the rotary encoder knob or use the UP or DOWN arrow keys to select “Acre Count Mode”. Press the knob or ENTER key.

D02200618

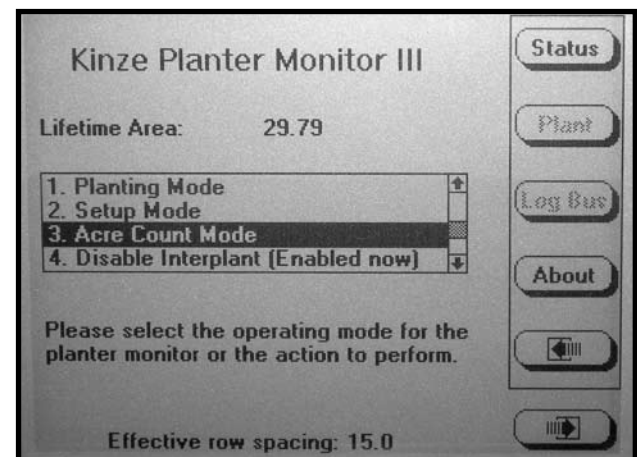

NOTE: If no radar unit is detected a warning will appear.

NOTE: If using acre count mode, area (acres or hectares) is accumulated in “Lifetime Area Counter”.

NOTE: DO NOT BEGIN ACCUMULATING AREA IF THE RADAR UNIT HAS NOT BEEN CALIBRATED. Always check the distance pulse count value immediately after entering acre count mode and before pressing start.

STEP 2 In the menu, “Units & Width” will be highlighted. Press the knob or ENTER key.

D02200619

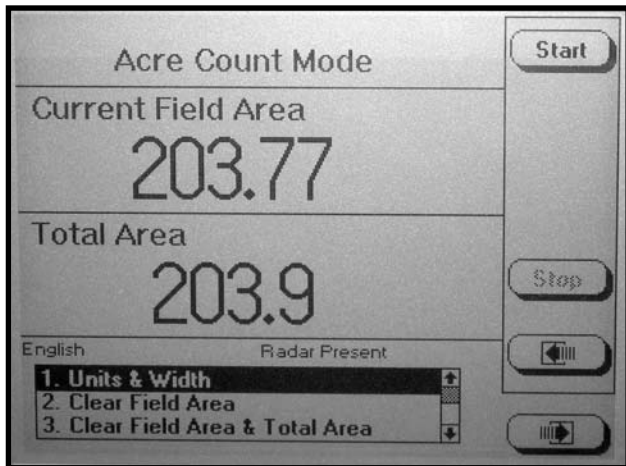

STEP 3 A drop down menu will appear. Select the correct units of measure “English” or “Metric” by turning the knob or using the UP or DOWN arrow keys. Press the knob or ENTER key to make the selection. The black box will advance to “Implement Width” field showing implement width in feet.

D02200621

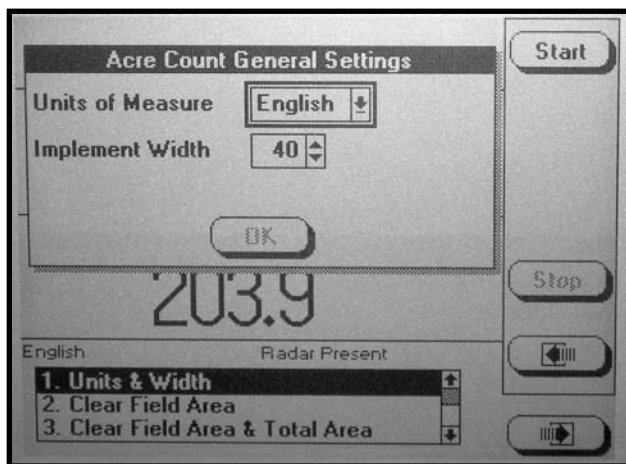

STEP 4 Press the knob or ENTER key to highlight the field. Turn the knob or use the UP or DOWN arrow keys to select desired number in feet. When desired number is obtained press the knob or ENTER key. The black box will advance to OK key.

NOTE: The implement width entered in acre count mode has no effect on planting mode settings.

STEP 5 Press the knob or ENTER key when done.

NOTE: Tractor should be at a complete stop before starting.

STEP 6 To begin accumulating area press the START key.

STEP 7 To stop accumulating area or to move to a different location, press the STOP key.

There are two counters in the Acre Count Mode (Field Area Counter and Total Area Counter). The “Field Area” counter can be cleared independent of the “Total Area” counter. Clearing the “Total Area” counter causes the “Field Area” counter to also be cleared.

- To Clear Field Area. Highlight “Clear Field Area” and press the knob or ENTER key. A note will appear verifying the decision to reset the field area to zero. Select OK and press the knob or ENTER key to clear the field to zero. Select Cancel and press the knob or the ENTER key to retain the current field value.

- To Clear Both Field Area And Total Area. Highlight the “Clear Field Area & Total Area” and press the knob or ENTER key. A note will appear to verify the decision to reset the field area and the total area to zero. Select OK and press the knob or ENTER key to clear the field to zero. Select CANCEL and press the knob or ENTER key to retain the current field value.

With planter reconnected to monitor return to normal plant screen by pressing the F6 key until the “Mode Selection” screen appears. Select “Planting Mode” by turning the knob or using the UP or DOWN arrow keys, press the knob or ENTER key.

REPLACING FAULTY SENSOR(S)

To replace a single faulty sensor: (a) turn OFF the monitor, (b) replace the sensor, (c) turn monitor ON. It will then recognize that a single sensor has been replaced.

NOTE: Monitor will beep twice when the new sensor(s) is learned.

To replace more than one faulty sensor:

- STEP 1** Press F6 key until the “Mode Selection” screen appears.
- STEP 2** Select “Setup Mode” by turning the knob or press the UP or DOWN arrow keys. Press the knob or ENTER key to display the highlighted item.
- STEP 3** Select “Sensor Setup” by turning the knob or using the UP or DOWN arrow keys. Press the knob or ENTER key to display the highlighted item.

D02140641

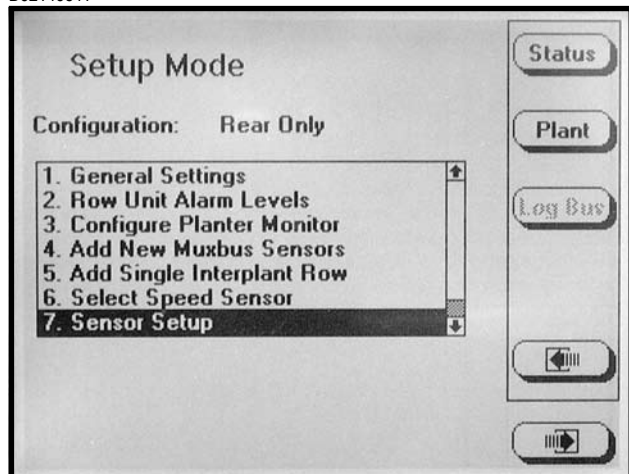

- STEP 4** Highlight faulty sensor. Press REMOVE key and unplug sensor. Plug in new sensor and press INSTALL key.

Repeat above procedure for each faulty sensor being replaced.

D02210601a

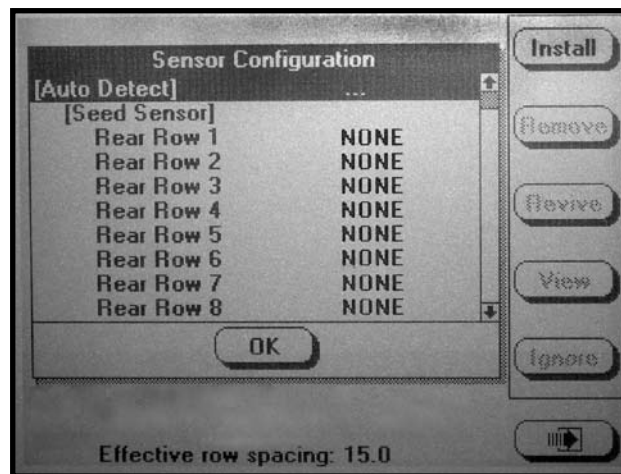

NOTE: Highlighting a sensor and pressing VIEW gives additional information when troubleshooting a problem. If a faulty sensor has been ignored it may be highlighted in the list of sensors, press REVIVE. The monitor will try to communicate with the sensor. If successful, “OK” will appear next to the sensor.

- STEP 5** Press the knob or ENTER key to return to “Setup Mode” screen.
- STEP 6** To return to “Planting Mode” press the PLANT key.

CONTENTS LISTINGS

IS676

MODEL 3000 Pull Type (Mechanical Seed Metering)	4 Row	6 Row	8 Row
KPM III Monitor Package Magnetic Distance Sensor	700-05142	700-05144	700-05146
KPM III Monitor Package Radar Distance Sensor	700-05143	700-05145	700-05147
Interplant® Monitor Package	700-05114	700-05115	700-05116

MODEL 3110 3 Pt. Mounted Rigid Frame (Mechanical Seed Metering)	8 Row	12 Row
KPM III Monitor Package Magnetic Distance Sensor	700-05144	700-05146
KPM III Monitor Package Radar Distance Sensor	700-05145	700-05147

MODEL 3140 3 Pt. Mounted Stack Folding (Mechanical Seed Metering)	8 Row	12 Row	16 Row
KPM III Monitor Package Magnetic Distance Sensor	700-05150	700-05155	700-05161
KPM III Monitor Package Radar Distance Sensor	700-05151	700-05156	700-05162

MODEL 3200 Flex Econo-Fold® (Mechanical Seed Metering)	12 Row
KPM III Monitor Package Magnetic Distance Sensor	700-05159
KPM III Monitor Package Radar Distance Sensor	700-05154

MODEL 3400 Twin-Line® (Mechanical Seed Metering)	12 Row
KPM III Monitor Package Magnetic Distance Sensor	700-05157
KPM III Monitor Package Radar Distance Sensor	700-05158
Interplant® Monitor Package	700-05117

MODEL 3500 Twin-Line® (Mechanical Seed Metering)	6 Row	8 Row
KPM III Monitor Package Magnetic Distance Sensor	700-05144	700-05146
KPM III Monitor Package Radar Distance Sensor	700-05145	700-05147
Interplant® Monitor Package	700-05115	700-05116

CONTENTS LISTINGS

IS676

MODEL 3600 Twin-Line® (Mechanical Seed Metering)	8 Row	12 Row	16 Row
KPM III Monitor Package Magnetic Distance Sensor	700-05152	700-05159	700-05163
KPM III Monitor Package Radar Distance Sensor	700-05149	700-05154	700-05164
Interplant® Monitor Package	700-05116	700-05117	700-05118

MODEL 3600TR Twin-Line® (Mechanical Seed Metering)	12 Row (24 Row)	16 Row (32 Row)
KPM III Monitor Package Magnetic Distance Sensor	700-05257	700-05258
KPM III Monitor Package Radar Distance Sensor	700-05259	700-05260

MODEL 3650 Twin-Line® (Mechanical Seed Metering)	12 Row	16 Row
KPM III Monitor Package Magnetic Distance Sensor	700-05159	700-05163
KPM III Monitor Package Radar Distance Sensor	700-05154	700-05164
Interplant® Monitor Package	700-05117	700-05118

MODEL 3700 Front Folding (Mechanical Seed Metering)	16 Row	24 Row	36 Row
KPM III Monitor Package Magnetic Distance Sensor	700-05165	700-05167	700-05173
KPM III Monitor Package Radar Distance Sensor	700-05166	700-05168	700-05174

MODEL 3800 Forward Folding (Mechanical Seed Metering)	24 Row	32 Row	36 Row
KPM III Monitor Package Magnetic Distance Sensor	700-05169	700-05171	700-05175
KPM III Monitor Package Radar Distance Sensor	700-05170	700-05172	700-05176

CONTENTS LISTINGS

IS676

MODEL 3000 Pull Type (EdgeVac® Seed Metering)	4 Row	6 Row	8 Row
KPM III Monitor Package Magnetic Distance Sensor	700-05177	700-05179	700-05181
KPM III Monitor Package Radar Distance Sensor	700-05178	700-05180	700-05182
Interplant® Monitor Package	700-05252	700-05253	700-05254

MODEL 3110 3 Pt. Mounted Rigid Frame (EdgeVac® Seed Metering)	6 Row	8 Row
KPM III Monitor Package Magnetic Distance Sensor	700-05179	700-05181
KPM III Monitor Package Radar Distance Sensor	700-05180	700-05182

MODEL 3140 3 Pt. Mounted Stack Folding (EdgeVac® Seed Metering)	8 Row	12 Row	16 Row
KPM III Monitor Package Magnetic Distance Sensor	700-05184	700-05188	700-05193
KPM III Monitor Package Radar Distance Sensor	700-05185	700-05189	700-05194

MODEL 3200 Flex Econo-Fold® (EdgeVac® Seed Metering)	12 Row
KPM III Monitor Package Magnetic Distance Sensor	700-05192
KPM III Monitor Package Radar Distance Sensor	700-05187

MODEL 3400 Twin-Line® (EdgeVac® Seed Metering)	12 Row
KPM III Monitor Package Magnetic Distance Sensor	700-05190
KPM III Monitor Package Radar Distance Sensor	700-05191
Interplant® Monitor Package	700-05255

CONTENTS LISTINGS

IS676

MODEL 3500 Twin-Line® (EdgeVac® Seed Metering)	6 Row	8 Row
KPM III Monitor Package Magnetic Distance Sensor	700-05179	700-05181
KPM III Monitor Package Radar Distance Sensor	700-05180	700-05182
Interplant® Monitor Package	700-05253	700-05254

MODEL 3600 Twin-Line® (EdgeVac® Seed Metering)	8 Row	12 Row	16 Row
KPM III Monitor Package Magnetic Distance Sensor	700-05186	700-05192	700-05195
KPM III Monitor Package Radar Distance Sensor	700-05183	700-05187	700-05196
Interplant® Monitor Package	700-05254	700-05255	700-05256

MODEL 3600TR Twin-Line® (EdgeVac® Seed Metering)	12 Row (24 Row)	16 Row (32 Row)
KPM III Monitor Package Magnetic Distance Sensor	700-05262	700-05263
KPM III Monitor Package Radar Distance Sensor	700-05264	700-05265

MODEL 3650 Twin-Line® (EdgeVac® Seed Metering)	12 Row	16 Row
KPM III Monitor Package Magnetic Distance Sensor	700-05192	700-05195
KPM III Monitor Package Radar Distance Sensor	700-05187	700-05196
Interplant® Monitor Package	700-05255	700-05256

MODEL 3700 Front Folding (EdgeVac® Seed Metering)	16 Row	24 Row	36 Row
KPM III Monitor Package Magnetic Distance Sensor	700-05197	700-05199	700-05205
KPM III Monitor Package Radar Distance Sensor	700-05198	700-05200	700-05206

MODEL 3800 Forward Folding (EdgeVac® Seed Metering)	24 Row	32 Row	36 Row
KPM III Monitor Package Magnetic Distance Sensor	700-05201	700-05203	700-05207
KPM III Monitor Package Radar Distance Sensor	700-05202	700-05204	700-05208

4 ROW SIZES (Mechanical Seed Metering)

KPM III Monitor Package, 4 Row - 700-05142 (With Magnetic Distance Sensor)

Model 3000

- (1)IS676 Instructions
- (1)IS673 Quick Reference Guide
- (1)A11039 Backlit Console
- (1)A8021 Planter Harness W/Dust Caps (4 Row)
- (4)A10901 Seed Tube W/Sensor
- (1)A6147 Sensor And Mounting Package
- (1)A7859 MDS Adapter
- (1)A8143 50 Pc. Pkg. (D1512) Tie Straps

KPM III Monitor Package, 4 Row - 700-05143 (With Radar Distance Sensor)

Model 3000

- (1)IS676 Instructions
- (1)IS673 Quick Reference Guide
- (1)A11039 Backlit Console
- (1)A8021 Planter Harness W/Dust Caps (4 Row)
- (4)A10901 Seed Tube W/Sensor
- (1)A7858 Radar Sensor
- (1)A8026 Radar Pipe/Mounting Bracket Package
- (1)A8143 50 Pc. Pkg. (D1512) Tie Straps

4 ROW SIZES (EdgeVac® Seed Metering)

KPM III Monitor Package, 4 Row - 700-05177 (With Magnetic Distance Sensor)

Model 3000

- (1)IS676 Instructions
- (1)IS673 Quick Reference Guide
- (1)A11039 Backlit Console
- (1)A8021 Planter Harness W/Dust Caps (4 Row)
- (4)A12650 Seed Tube W/Sensor
- (1)A6147 Sensor And Mounting Package
- (1)A7859 MDS Adapter
- (1)A8143 50 Pc. Pkg. (D1512) Tie Straps

KPM III Monitor Package, 4 Row - 700-05178 (With Radar Distance Sensor)

Model 3000

- (1)IS676 Instructions
- (1)IS673 Quick Reference Guide
- (1)A11039 Backlit Console
- (1)A8021 Planter Harness W/Dust Caps (4 Row)
- (4)A12650 Seed Tube W/Sensor
- (1)A7858 Radar Sensor
- (1)A8026 Radar Pipe/Mounting Bracket Package
- (1)A8143 50 Pc. Pkg. (D1512) Tie Straps

6 ROW SIZES (Mechanical Seed Metering)

KPM III Monitor Package, 6 Row - 700-05144 (With Magnetic Distance Sensor)

Models 3000, 3110 Rigid Frame And 3500

- (1)IS676 Instructions
- (1)IS673 Quick Reference Guide
- (1)A11039 Backlit Console
- (1)A8022 Planter Harness W/Dust Caps (6 Row)
- (6)A10901 Seed Tube W/Sensor
- (1)A6147 Sensor And Mounting Package
- (1)A7859 MDS Adapter
- (1)A8143 50 Pc. Pkg. (D1512) Tie Straps

KPM III Monitor Package, 6 Row - 700-05145 (With Radar Distance Sensor)

Models 3000, 3110 Rigid Frame And 3500

- (1)IS676 Instructions
- (1)IS673 Quick Reference Guide
- (1)A11039 Backlit Console
- (1)A8022 Planter Harness W/Dust Caps (6 Row)
- (6)A10901 Seed Tube W/Sensor
- (1)A7858 Radar Sensor
- (1)A8026 Radar Pipe/Mounting Bracket Package
- (1)A8143 50 Pc. Pkg. (D1512) Tie Straps

6 ROW SIZES (EdgeVac® Seed Metering)

KPM III Monitor Package, 6 Row - 700-05179 (With Magnetic Distance Sensor)

Models 3000, 3110 Rigid Frame And 3500

- (1)IS676 Instructions
- (1)IS673 Quick Reference Guide
- (1)A11039 Backlit Console
- (1)A8022 Planter Harness W/Dust Caps (6 Row)
- (6)A12650 Seed Tube W/Sensor
- (1)A6147 Sensor And Mounting Package
- (1)A7859 MDS Adapter
- (1)A8143 50 Pc. Pkg. (D1512) Tie Straps

KPM III Monitor Package, 6 Row - 700-05180 (With Radar Distance Sensor)

Models 3000, 3110 Rigid Frame And 3500

- (1)IS676 Instructions
- (1)IS673 Quick Reference Guide
- (1)A11039 Backlit Console
- (1)A8022 Planter Harness W/Dust Caps (6 Row)
- (6)A12650 Seed Tube W/Sensor
- (1)A7858 Radar Sensor
- (1)A8026 Radar Pipe/Mounting Bracket Package
- (1)A8143 50 Pc. Pkg. (D1512) Tie Straps

8 ROW SIZES (Mechanical Seed Metering)

KPM III Monitor Package, 8 Row - 700-05152 (With Magnetic Distance Sensor)

Model 3600

(1)IS676	Instructions
(1)IS673	Quick Reference Guide
(1)A11039	Backlit Console
(1)A7850	Planter Harness W/Dust Caps (8 Row)
(8)A10901	Seed Tube W/Sensor
(1)A6147	Sensor And Mounting Package
(1)A7859	MDS Adapter
(1)A12694	Drill Shaft Sensor Mounting Kit
(1)A8135	Drill Shaft Rotation Sensor Kit
(1)A8143	50 Pc. Pkg. (D1512) Tie Straps

KPM III Monitor Package, 8 Row - 700-05146 (With Magnetic Distance Sensor)

Models 3000, 3110 Rigid Frame And 3500

(1)IS676	Instructions
(1)IS673	Quick Reference Guide
(1)A11039	Backlit Console
(1)A7850	Planter Harness W/Dust Caps (8 Row)
(8)A10901	Seed Tube W/Sensor
(1)A6147	Sensor And Mounting Package
(1)A7859	MDS Adapter
(1)A8143	50 Pc. Pkg. (D1512) Tie Straps

KPM III Monitor Package, 8 Row - 700-05150 (With Magnetic Distance Sensor)

Model 3140 Stack Folding

(1)IS676	Instructions
(1)IS673	Quick Reference Guide
(1)A11039	Backlit Console
(2)A7849	Extension Harness W/Female Connectors, 15'
(1)A8022	Planter Harness W/Dust Caps (6 Row)
(2)A8021	Planter Harness W/Dust Caps (4 Row)
(8)A10901	Seed Tube W/Sensor
(1)A6147	Sensor And Mounting Package
(1)A7859	MDS Adapter
(1)A12694	Drill Shaft Sensor Mounting Kit
(1)A8135	Drill Shaft Rotation Sensor Kit
(1)A8143	50 Pc. Pkg. (D1512) Tie Straps

KPM III Monitor Package, 8 Row - 700-05149 (With Radar Distance Sensor)

Model 3600

(1)IS676	Instructions
(1)IS673	Quick Reference Guide
(1)A11039	Backlit Console
(1)A7850	Planter Harness W/Dust Caps (8 Row)
(8)A10901	Seed Tube W/Sensor
(1)A7858	Radar Sensor
(1)A12694	Drill Shaft Sensor Mounting Kit
(1)A8135	Drill Shaft Rotation Sensor Kit
(1)A8026	Radar Pipe/Mounting Bracket Package
(1)A8143	50 Pc. Pkg. (D1512) Tie Straps

KPM III Monitor Package, 8 Row - 700-05147 (With Radar Distance Sensor)

Models 3110 Rigid Frame And 3500

(1)IS676	Instructions
(1)IS673	Quick Reference Guide
(1)A11039	Backlit Console
(1)A7850	Planter Harness W/Dust Caps (8 Row)
(8)A10901	Seed Tube W/Sensor
(1)A7858	Radar Sensor
(1)A8026	Radar Pipe/Mounting Bracket Package
(1)A8143	50 Pc. Pkg. (D1512) Tie Straps

KPM III Monitor Package, 8 Row - 700-05151 (With Radar Distance Sensor)

Model 3140 Stack Folding

(1)IS676	Instructions
(1)IS673	Quick Reference Guide
(1)A11039	Backlit Console
(2)A7849	Extension Harness W/Female Connectors, 15'
(1)A8022	Planter Harness W/Dust Caps (6 Row)
(2)A8021	Planter Harness W/Dust Caps (4 Row)
(8)A10901	Seed Tube W/Sensor
(1)A7858	Radar Sensor
(1)A12694	Drill Shaft Sensor Mounting Kit
(1)A8135	Drill Shaft Rotation Sensor Kit
(1)A8026	Radar Pipe/Mounting Bracket Package
(1)A8143	50 Pc. Pkg. (D1512) Tie Straps

8 ROW SIZES (EdgeVac® Seed Metering)

KPM III Monitor Package, 8 Row - 700-05186 (With Magnetic Distance Sensor)

Model 3600

- (1)IS676 Instructions
- (1)IS673 Quick Reference Guide
- (1)A11039 Backlit Console
- (1)A7850 Planter Harness W/Dust Caps (8 Row)
- (8)A12650 Seed Tube W/Sensor
- (1)A6147 Sensor And Mounting Package
- (1)A7859 MDS Adapter
- (1)A12694 Drill Shaft Sensor Mounting Kit
- (1)A8135 Drill Shaft Rotation Sensor Kit
- (1)A8143 50 Pc. Pkg. (D1512) Tie Straps

KPM III Monitor Package, 8 Row - 700-05181 (With Magnetic Distance Sensor)

Models 3000, 3110 Rigid Frame And 3500

- (1)IS676 Instructions
- (1)IS673 Quick Reference Guide
- (1)A11039 Backlit Console
- (1)A7850 Planter Harness W/Dust Caps (8 Row)
- (8)A12650 Seed Tube W/Sensor
- (1)A6147 Sensor And Mounting Package
- (1)A7859 MDS Adapter
- (1)A8143 50 Pc. Pkg. (D1512) Tie Straps

KPM III Monitor Package, 8 Row - 700-05184 (With Magnetic Distance Sensor)

Model 3140 Stack Folding

- (1)IS676 Instructions
- (1)IS673 Quick Reference Guide
- (1)A11039 Backlit Console
- (2)A7849 Extension Harness W/Female Connectors, 15'
- (1)A8022 Planter Harness W/Dust Caps (6 Row)
- (2)A8021 Planter Harness W/Dust Caps (4 Row)
- (8)A12650 Seed Tube W/Sensor
- (1)A6147 Sensor And Mounting Package
- (1)A7859 MDS Adapter
- (1)A12694 Drill Shaft Sensor Mounting Kit
- (1)A8135 Drill Shaft Rotation Sensor Kit
- (1)A8143 50 Pc. Pkg. (D1512) Tie Straps

KPM III Monitor Package, 8 Row - 700-05183 (With Radar Distance Sensor)

Model 3600

- (1)IS676 Instructions
- (1)IS673 Quick Reference Guide
- (1)A11039 Backlit Console
- (1)A7850 Planter Harness W/Dust Caps (8 Row)
- (8)A12650 Seed Tube W/Sensor
- (1)A7858 Radar Sensor
- (1)A12694 Drill Shaft Sensor Mounting Kit
- (1)A8135 Drill Shaft Rotation Sensor Kit
- (1)A8026 Radar Pipe/Mounting Bracket Package
- (1)A8143 50 Pc. Pkg. (D1512) Tie Straps

KPM III Monitor Package, 8 Row - 700-05182 (With Radar Distance Sensor)

Models 3110 Rigid Frame And 3500

- (1)IS676 Instructions
- (1)IS673 Quick Reference Guide
- (1)A11039 Backlit Console
- (1)A7850 Planter Harness W/Dust Caps (8 Row)
- (8)A12650 Seed Tube W/Sensor
- (1)A7858 Radar Sensor
- (1)A8026 Radar Pipe/Mounting Bracket Package
- (1)A8143 50 Pc. Pkg. (D1512) Tie Straps

KPM III Monitor Package, 8 Row - 700-05185 (With Radar Distance Sensor)

Model 3140 Stack Folding

- (1)IS676 Instructions
- (1)IS673 Quick Reference Guide
- (1)A11039 Backlit Console
- (2)A7849 Extension Harness W/Female Connectors, 15'
- (1)A8022 Planter Harness W/Dust Caps (6 Row)
- (2)A8021 Planter Harness W/Dust Caps (4 Row)
- (8)A12650 Seed Tube W/Sensor
- (1)A7858 Radar Sensor
- (1)A12694 Drill Shaft Sensor Mounting Kit
- (1)A8135 Drill Shaft Rotation Sensor Kit
- (1)A8026 Radar Pipe/Mounting Bracket Package
- (1)A8143 50 Pc. Pkg. (D1512) Tie Straps

12 ROW SIZES (Mechanical Seed Metering)

**KPM III Monitor Package, 12 Row - 700-05159
(With Magnetic Distance Sensor)**

Models 3200, 3600 And 3650

- (1)IS676 Instructions
- (1)IS673 Quick Reference Guide
- (1)A11039 Backlit Console
- (1)A7851 Planter Harness W/Dust Caps
(12 Row)
- (12)A10901 Seed Tube W/Sensor
- (1)A6147 Sensor And Mounting Package
- (1)A7859 MDS Adapter
- (1)A12694 Drill Shaft Sensor Mounting Kit
- (1)A8135 Drill Shaft Rotation Sensor Kit
- (2)A8143 50 Pc. Pkg. (D1512) Tie Straps

**KPM III Monitor Package, 12 Row - 700-05157
(With Magnetic Distance Sensor)**

Model 3400

- (1)IS676 Instructions
- (1)IS673 Quick Reference Guide
- (1)A11039 Backlit Console
- (1)A7851 Planter Harness W/Dust Caps
(12 Row)
- (12)A10901 Seed Tube W/Sensor
- (1)A6147 Sensor And Mounting Package
- (1)A7859 MDS Adapter
- (2)A8143 50 Pc. Pkg. (D1512) Tie Straps

**KPM III Monitor Package, 12 Row - 700-05155
(With Magnetic Distance Sensor)**

Model 3140 Stack Folding

- (1)IS676 Instructions
- (1)IS673 Quick Reference Guide
- (1)A11039 Backlit Console
- (2)A7849 Extension Harness W/Female
Connectors, 15'
- (1)A7850 Planter Harness W/Dust Caps (8 Row)
- (2)A8021 Planter Harness W/Dust Caps (4 Row)
- (12)A10901 Seed Tube W/Sensor
- (1)A6147 Sensor And Mounting Package
- (1)A7859 MDS Adapter
- (1)A12694 Drill Shaft Sensor Mounting Kit
- (1)A8135 Drill Shaft Rotation Sensor Kit
- (2)A8143 50 Pc. Pkg. (D1512) Tie Straps

**KPM III Monitor Package, 12 Row - 700-05154
(With Radar Distance Sensor)**

Models 3200, 3600 And 3650

- (1)IS676 Instructions
- (1)IS673 Quick Reference Guide
- (1)A11039 Backlit Console
- (1)A7851 Planter Harness W/Dust Caps (12 Row)
- (12)A10901 Seed Tube W/Sensor
- (1)A7858 Radar Sensor
- (1)A12694 Drill Shaft Sensor Mounting Kit
- (1)A8135 Drill Shaft Rotation Sensor Kit
- (1)A8026 Radar Pipe/Mounting Bracket Package
- (2)A8143 50 Pc. Pkg. (D1512) Tie Straps

**KPM III Monitor Package, 12 Row - 700-05156
(With Radar Distance Sensor)**

Model 3140 Stack Folding

- (1)IS676 Instructions
- (1)IS673 Quick Reference Guide
- (1)A11039 Backlit Console
- (2)A7849 Extension Harness W/Female Connectors, 15'
- (1)A7850 Planter Harness W/Dust Caps (8 Row)
- (2)A8021 Planter Harness W/Dust Caps (4 Row)
- (12)A10901 Seed Tube W/Sensor
- (1)A7858 Radar Gun
- (1)A12694 Drill Shaft Sensor Mounting Kit
- (1)A8135 Drill Shaft Rotation Sensor Kit
- (2)A8143 50 Pc. Pkg. (D1512) Tie Straps
- (1)A8026 Radar Sensor

**KPM III Monitor Package, 12 Row - 700-05158
(With Radar Distance Sensor)**

Model 3400

- (1)IS676 Instructions
- (1)IS673 Quick Reference Guide
- (1)A11039 Backlit Console
- (1)A7851 Planter Harness W/Dust Caps (12 Row)
- (12)A10901 Seed Tube W/Sensor
- (1)A7858 Radar Sensor
- (1)A8026 Radar Pipe/Mounting Bracket Package
- (2)A8143 50 Pc. Pkg. (D1512) Tie Straps

12 ROW SIZES (EdgeVac® Seed Metering)

KPM III Monitor Package, 12 Row - 700-05192 (With Magnetic Distance Sensor)

Models 3200, 3600 And 3650

- (1)IS676 Instructions
- (1)IS673 Quick Reference Guide
- (1)A11039 Backlit Console
- (1)A7851 Planter Harness W/Dust Caps (12 Row)
- (12)A12650 Seed Tube W/Sensor
- (1)A6147 Sensor And Mounting Package
- (1)A7859 MDS Adapter
- (1)A12694 Drill Shaft Sensor Mounting Kit
- (1)A8135 Drill Shaft Rotation Sensor Kit
- (2)A8143 50 Pc. Pkg. (D1512) Tie Straps

KPM III Monitor Package, 12 Row - 700-05190 (With Magnetic Distance Sensor)

Model 3400

- (1)IS676 Instructions
- (1)IS673 Quick Reference Guide
- (1)A11039 Backlit Console
- (1)A7851 Planter Harness W/Dust Caps (12 Row)
- (12)A12650 Seed Tube W/Sensor
- (1)A6147 Sensor And Mounting Package
- (1)A7859 MDS Adapter
- (2)A8143 50 Pc. Pkg. (D1512) Tie Straps

KPM III Monitor Package, 12 Row - 700-05188 (With Magnetic Distance Sensor)

Model 3140 Stack Folding

- (1)IS676 Instructions
- (1)IS673 Quick Reference Guide
- (1)A11039 Backlit Console
- (2)A7849 Extension Harness W/Female Connectors, 15'
- (1)A7850 Planter Harness W/Dust Caps (8 Row)
- (2)A8021 Planter Harness W/Dust Caps (4 Row)
- (12)A12650 Seed Tube W/Sensor
- (1)A6147 Sensor And Mounting Package
- (1)A7859 MDS Adapter
- (1)A12694 Drill Shaft Sensor Mounting Kit
- (1)A8135 Drill Shaft Rotation Sensor Kit
- (2)A8143 50 Pc. Pkg. (D1512) Tie Straps

KPM III Monitor Package, 12 Row - 700-05187 (With Radar Distance Sensor)

Models 3200, 3600 And 3650

- (1)IS676 Instructions
- (1)IS673 Quick Reference Guide
- (1)A11039 Backlit Console
- (1)A7851 Planter Harness W/Dust Caps (12 Row)
- (12)A12650 Seed Tube W/Sensor
- (1)A7858 Radar Sensor
- (1)A12694 Drill Shaft Sensor Mounting Kit
- (1)A8135 Drill Shaft Rotation Sensor Kit
- (1)A8026 Radar Pipe/Mounting Bracket Package
- (2)A8143 50 Pc. Pkg. (D1512) Tie Straps

KPM III Monitor Package, 12 Row - 700-05189 (With Radar Distance Sensor)

Model 3140 Stack Folding

- (1)IS676 Instructions
- (1)IS673 Quick Reference Guide
- (1)A11039 Backlit Console
- (2)A7849 Extension Harness W/Female Connectors, 15'
- (1)A7850 Planter Harness W/Dust Caps (8 Row)
- (2)A8021 Planter Harness W/Dust Caps (4 Row)
- (12)A12650 Seed Tube W/Sensor
- (1)A7858 Radar Gun
- (1)A12694 Drill Shaft Sensor Mounting Kit
- (1)A8135 Drill Shaft Rotation Sensor Kit
- (2)A8143 50 Pc. Pkg. (D1512) Tie Straps
- (1)A8026 Radar Sensor

KPM III Monitor Package, 12 Row - 700-05191 (With Radar Distance Sensor)

Model 3400

- (1)IS676 Instructions
- (1)IS673 Quick Reference Guide
- (1)A11039 Backlit Console
- (1)A7851 Planter Harness W/Dust Caps (12 Row)
- (12)A12650 Seed Tube W/Sensor
- (1)A7858 Radar Sensor
- (1)A8026 Radar Pipe/Mounting Bracket Package
- (2)A8143 50 Pc. Pkg. (D1512) Tie Straps

16 ROW SIZES (Mechanical Seed Metering)

KPM III Monitor Package, 16 Row - 700-05163 (With Magnetic Distance Sensor)

Models 3600 And 3650

- (1)IS676 Instructions
- (1)IS673 Quick Reference Guide
- (1)A11039 Backlit Console
- (1)A7852 Planter Harness W/Dust Caps (16 Row)
- (16)A10901 Seed Tube W/Sensor
- (1)A6147 Sensor And Mounting Package
- (1)A7859 MDS Adapter
- (1)A12694 Drill Shaft Sensor Mounting Kit
- (1)A8135 Drill Shaft Rotation Sensor Kit
- (3)A8143 50 Pc. Pkg. (D1512) Tie Straps

KPM III Monitor Package, 16 Row - 700-05165 (With Magnetic Distance Sensor)

Model 3700

- (1)IS676 Instructions
- (1)IS673 Quick Reference Guide
- (1)A11039 Backlit Console
- (2)A7850 Planter Harness W/Dust Caps (8 Row)
- (16)A10901 Seed Tube W/Sensor
- (1)A6147 Sensor And Mounting Package
- (1)A7859 MDS Adapter
- (1)A12694 Drill Shaft Sensor Mounting Kit
- (1)A8135 Drill Shaft Rotation Sensor Kit
- (3)A8143 50 Pc. Pkg. (D1512) Tie Straps

KPM III Monitor Package, 16 Row - 700-05161 (With Magnetic Distance Sensor)

Model 3140 Stack Folding

- (1)IS676 Instructions
- (1)IS673 Quick Reference Guide
- (1)A11039 Backlit Console
- (2)A7849 Extension Harness W/Female Connectors, 15'
- (1)A7851 Planter Harness W/Dust Caps (12 Row)
- (2)A8021 Planter Harness W/Dust Caps (4 Row)
- (16)A10901 Seed Tube W/Sensor
- (1)A6147 Sensor And Mounting Package
- (1)A7859 MDS Adapter
- (1)A12694 Drill Shaft Sensor Mounting Kit
- (1)A8135 Drill Shaft Rotation Sensor Kit
- (3)A8143 50 Pc. Pkg. (D1512) Tie Straps

KPM III Monitor Package, 16 Row - 700-05164 (With Radar Distance Sensor)

Models 3600 And 3650

- (1)IS676 Instructions
- (1)IS673 Quick Reference Guide
- (1)A11039 Backlit Console
- (1)A7852 Planter Harness W/Dust Caps (16 Row)
- (16)A10901 Seed Tube W/Sensor
- (1)A7858 Radar Sensor
- (1)A12694 Drill Shaft Sensor Mounting Kit
- (1)A8135 Drill Shaft Rotation Sensor Kit
- (1)A8026 Radar Pipe/Mounting Bracket Package
- (3)A8143 50 Pc. Pkg. (D1512) Tie Straps

KPM III Monitor Package, 16 Row - 700-05166 (With Radar Distance Sensor)

Model 3700

- (1)IS676 Instructions
- (1)IS673 Quick Reference Guide
- (1)A11039 Backlit Console
- (2)A7850 Planter Harness W/Dust Caps (8 Row)
- (16)A10901 Seed Tube W/Sensor
- (1)A7858 Radar Sensor
- (1)A12694 Drill Shaft Sensor Mounting Kit
- (1)A8135 Drill Shaft Rotation Sensor Kit
- (1)A8026 Radar Pipe/Mounting Bracket Package
- (3)A8143 50 Pc. Pkg. (D1512) Tie Straps

KPM III Monitor Package, 16 Row - 700-05162 (With Radar Distance Sensor)

Model 3140 Stack Folding

- (1)IS676 Instructions
- (1)IS673 Quick Reference Guide
- (1)A11039 Backlit Console
- (2)A7849 Extension Harness W/Female Connectors, 15'
- (1)A7851 Planter Harness W/Dust Caps (12 Row)
- (2)A8021 Planter Harness W/Dust Caps (4 Row)
- (16)A10901 Seed Tube W/Sensor
- (1)A7858 Radar Sensor
- (1)A12694 Drill Shaft Sensor Mounting Kit
- (1)A8135 Drill Shaft Rotation Sensor Kit
- (1)A8026 Radar Pipe/Mounting Bracket Package
- (3)A8143 50 Pc. Pkg. (D1512) Tie Straps

16 ROW SIZES (EdgeVac® Seed Metering)

KPM III Monitor Package, 16 Row - 700-05195 (With Magnetic Distance Sensor)

Models 3600 And 3650

- (1)IS676 Instructions
- (1)IS673 Quick Reference Guide
- (1)A11039 Backlit Console
- (1)A7852 Planter Harness W/Dust Caps (16 Row)
- (16)A12650 Seed Tube W/Sensor
- (1)A6147 Sensor And Mounting Package
- (1)A7859 MDS Adapter
- (1)A12694 Drill Shaft Sensor Mounting Kit
- (1)A8135 Drill Shaft Rotation Sensor Kit
- (3)A8143 50 Pc. Pkg. (D1512) Tie Straps

KPM III Monitor Package, 16 Row - 700-05197 (With Magnetic Distance Sensor)

Model 3700

- (1)IS676 Instructions
- (1)IS673 Quick Reference Guide
- (1)A11039 Backlit Console
- (2)A7850 Planter Harness W/Dust Caps (8 Row)
- (16)A12650 Seed Tube W/Sensor
- (1)A6147 Sensor And Mounting Package
- (1)A7859 MDS Adapter
- (1)A12694 Drill Shaft Sensor Mounting Kit
- (1)A8135 Drill Shaft Rotation Sensor Kit
- (3)A8143 50 Pc. Pkg. (D1512) Tie Straps

KPM III Monitor Package, 16 Row - 700-05193 (With Magnetic Distance Sensor)

Model 3140 Stack Folding

- (1)IS676 Instructions
- (1)IS673 Quick Reference Guide
- (1)A11039 Backlit Console
- (2)A7849 Extension Harness W/Female Connectors, 15'
- (1)A7851 Planter Harness W/Dust Caps (12 Row)
- (2)A8021 Planter Harness W/Dust Caps (4 Row)
- (16)A12650 Seed Tube W/Sensor
- (1)A6147 Sensor And Mounting Package
- (1)A7859 MDS Adapter
- (1)A12694 Drill Shaft Sensor Mounting Kit
- (1)A8135 Drill Shaft Rotation Sensor Kit
- (3)A8143 50 Pc. Pkg. (D1512) Tie Straps

KPM III Monitor Package, 16 Row - 700-05196 (With Radar Distance Sensor)

Models 3600 And 3650

- (1)IS676 Instructions
- (1)IS673 Quick Reference Guide
- (1)A11039 Backlit Console
- (1)A7852 Planter Harness W/Dust Caps (16 Row)
- (16)A12650 Seed Tube W/Sensor
- (1)A7858 Radar Sensor
- (1)A12694 Drill Shaft Sensor Mounting Kit
- (1)A8135 Drill Shaft Rotation Sensor Kit
- (1)A8026 Radar Pipe/Mounting Bracket Package
- (3)A8143 50 Pc. Pkg. (D1512) Tie Straps

KPM III Monitor Package, 16 Row - 700-05198 (With Radar Distance Sensor)

Model 3700

- (1)IS676 Instructions
- (1)IS673 Quick Reference Guide
- (1)A11039 Backlit Console
- (2)A7850 Planter Harness W/Dust Caps (8 Row)
- (16)A12650 Seed Tube W/Sensor
- (1)A7858 Radar Sensor
- (1)A12694 Drill Shaft Sensor Mounting Kit
- (1)A8135 Drill Shaft Rotation Sensor Kit
- (1)A8026 Radar Pipe/Mounting Bracket Package
- (3)A8143 50 Pc. Pkg. (D1512) Tie Straps

KPM III Monitor Package, 16 Row - 700-05194 (With Radar Distance Sensor)

Model 3140 Stack Folding

- (1)IS676 Instructions
- (1)IS673 Quick Reference Guide
- (1)A11039 Backlit Console
- (2)A7849 Extension Harness W/Female Connectors, 15'
- (1)A7851 Planter Harness W/Dust Caps (12 Row)
- (2)A8021 Planter Harness W/Dust Caps (4 Row)
- (16)A12650 Seed Tube W/Sensor
- (1)A7858 Radar Sensor
- (1)A12694 Drill Shaft Sensor Mounting Kit
- (1)A8135 Drill Shaft Rotation Sensor Kit
- (1)A8026 Radar Pipe/Mounting Bracket Package
- (3)A8143 50 Pc. Pkg. (D1512) Tie Straps

24 ROW SIZES (Mechanical Seed Metering)

KPM III Monitor Package, 24 Row - 700-05257 (With Magnetic Distance Sensor)

Model 3600TR 12 RN

- (1)IS676 Instructions
- (1)IS673 Quick Reference Guide
- (1)A11039 Backlit Console
- (2)A7851 Planter Harness W/Dust Caps (12 Row)
- (24)A10901 Seed Tube W/Sensor
- (1)A6147 Sensor And Mounting Package
- (1)A7859 MDS Adapter
- (1)A8135 Drill Shaft Rotation Sensor Kit
- (3)A8143 50 Pc. Pkg. (D1512) Tie Straps
- (1)A7853 Junction Y-Harness W/Dust Cap
- (1)A12694 Drill Shaft Sensor Mounting Kit

KPM III Monitor Package, 24 Row - 700-05167 (With Magnetic Distance Sensor)

Model 3700

- (1)IS676 Instructions
- (1)IS673 Quick Reference Guide
- (1)A11039 Backlit Console
- (2)A7851 Planter Harness W/Dust Caps (12 Row)
- (24)A10901 Seed Tube W/Sensor
- (1)A6147 Sensor And Mounting Package
- (1)A7859 MDS Adapter
- (1)A12694 Drill Shaft Sensor Mounting Kit
- (1)A8135 Drill Shaft Rotation Sensor Kit
- (3)A8143 50 Pc. Pkg. (D1512) Tie Straps

KPM III Monitor Package, 24 Row - 700-05169 (With Magnetic Distance Sensor)

Model 3800

- (1)IS676 Instructions
- (1)IS673 Quick Reference Guide
- (1)A11039 Backlit Console
- (2)A7851 Planter Harness W/Dust Caps (12 Row)
- (1)A8022 Planter Harness W/Dust Caps (6 Row)
- (24)A10901 Seed Tube W/Sensor
- (1)A6147 Sensor And Mounting Package
- (1)A7859 MDS Adapter
- (2)A12694 Drill Shaft Sensor Mounting Kit
- (2)A8135 Drill Shaft Rotation Sensor Kit
- (1)A7849 Extension Harness W/Female Connectors, 15'
- (4)A8143 50 Pc. Pkg. (D1512) Tie Straps

KPM III Monitor Package, 24 Row - 700-05259 (With Radar Distance Sensor)

Model 3600TR 12 RN

- (1)IS676 Instructions
- (1)IS673 Quick Reference Guide
- (1)A11039 Backlit Console
- (2)A7851 Planter Harness W/Dust Caps (12 Row)
- (24)A10901 Seed Tube W/Sensor
- (1)A7858 Radar Sensor
- (1)A8135 Drill Shaft Rotation Sensor Kit
- (1)A8026 Radar Pipe/Mounting Bracket Package
- (3)A8143 50 Pc. Pkg. (D1512) Tie Straps
- (1)A7853 Junction Y-Harness W/Dust Cap
- (1)A12694 Drill Shaft Sensor Mounting Kit

KPM III Monitor Package, 24 Row - 700-05168 (With Radar Distance Sensor)

Model 3700

- (1)IS676 Instructions
- (1)IS673 Quick Reference Guide
- (1)A11039 Backlit Console
- (2)A7851 Planter Harness W/Dust Caps (12 Row)
- (24)A10901 Seed Tube W/Sensor
- (1)A7858 Radar Sensor
- (1)A12694 Drill Shaft Sensor Mounting Kit
- (1)A8135 Drill Shaft Rotation Sensor Kit
- (1)A8026 Radar Pipe/Mounting Bracket Package
- (3)A8143 50 Pc. Pkg. (D1512) Tie Straps

KPM III Monitor Package, 24 Row - 700-05170 (With Radar Distance Sensor)

Model 3800

- (1)IS676 Instructions
- (1)IS673 Quick Reference Guide
- (1)A11039 Backlit Console
- (2)A7851 Planter Harness W/Dust Caps (12 Row)
- (1)A8022 Planter Harness W/Dust Caps (6 Row)
- (24)A10901 Seed Tube W/Sensor
- (1)A7858 Radar Sensor
- (2)A12694 Drill Shaft Sensor Mounting Kit
- (2)A8135 Drill Shaft Rotation Sensor Kit
- (1)A8026 Radar Pipe/Mounting Bracket Package
- (1)A7849 Extension Harness W/Female Connectors, 15'
- (4)A8143 50 Pc. Pkg. (D1512) Tie Straps

24 ROW SIZES (EdgeVac® Seed Metering)

KPM III Monitor Package, 24 Row - 700-05262 (With Magnetic Distance Sensor)

Model 3600TR 12 RN

- (1)IS676 Instructions
- (1)IS673 Quick Reference Guide
- (1)A11039 Backlit Console
- (2)A7851 Planter Harness W/Dust Caps (12 Row)
- (24)A12650 Seed Tube W/Sensor
- (1)A6147 Sensor And Mounting Package
- (1)A7859 MDS Adapter
- (1)A8135 Drill Shaft Rotation Sensor Kit
- (3)A8143 50 Pc. Pkg. (D1512) Tie Straps
- (1)A7853 Junction Y-Harness W/Dust Cap
- (1)A12694 Drill Shaft Sensor Mounting Kit

KPM III Monitor Package, 24 Row - 700-05199 (With Magnetic Distance Sensor)

Model 3700

- (1)IS676 Instructions
- (1)IS673 Quick Reference Guide
- (1)A11039 Backlit Console
- (2)A7851 Planter Harness W/Dust Caps (12 Row)
- (24)A12650 Seed Tube W/Sensor
- (1)A6147 Sensor And Mounting Package
- (1)A7859 MDS Adapter
- (1)A12694 Drill Shaft Sensor Mounting Kit
- (1)A8135 Drill Shaft Rotation Sensor Kit
- (3)A8143 50 Pc. Pkg. (D1512) Tie Straps

KPM III Monitor Package, 24 Row - 700-05201 (With Magnetic Distance Sensor)

Model 3800

- (1)IS676 Instructions
- (1)IS673 Quick Reference Guide
- (1)A11039 Backlit Console
- (2)A7851 Planter Harness W/Dust Caps (12 Row)
- (1)A8022 Planter Harness W/Dust Caps (6 Row)
- (24)A12650 Seed Tube W/Sensor
- (1)A6147 Sensor And Mounting Package
- (1)A7859 MDS Adapter
- (2)A12694 Drill Shaft Sensor Mounting Kit
- (2)A8135 Drill Shaft Rotation Sensor Kit
- (1)A7849 Extension Harness W/Female Connectors, 15'
- (4)A8143 50 Pc. Pkg. (D1512) Tie Straps

KPM III Monitor Package, 24 Row - 700-05264 (With Radar Distance Sensor)

Model 3600TR 12 RN

- (1)IS676 Instructions
- (1)IS673 Quick Reference Guide
- (1)A11039 Backlit Console
- (2)A7851 Planter Harness W/Dust Caps (12 Row)
- (24)A12650 Seed Tube W/Sensor
- (1)A7858 Radar Sensor
- (1)A8135 Drill Shaft Rotation Sensor Kit
- (1)A8026 Radar Pipe/Mounting Bracket Package
- (3)A8143 50 Pc. Pkg. (D1512) Tie Straps
- (1)A7853 Junction Y-Harness W/Dust Cap
- (1)A12694 Drill Shaft Sensor Mounting Kit

KPM III Monitor Package, 24 Row - 700-05200 (With Radar Distance Sensor)

Model 3700

- (1)IS676 Instructions
- (1)IS673 Quick Reference Guide
- (1)A11039 Backlit Console
- (2)A7851 Planter Harness W/Dust Caps (12 Row)
- (24)A12650 Seed Tube W/Sensor
- (1)A7858 Radar Sensor
- (1)A12694 Drill Shaft Sensor Mounting Kit
- (1)A8135 Drill Shaft Rotation Sensor Kit
- (1)A8026 Radar Pipe/Mounting Bracket Package
- (3)A8143 50 Pc. Pkg. (D1512) Tie Straps

KPM III Monitor Package, 24 Row - 700-05202 (With Radar Distance Sensor)

Model 3800

- (1)IS676 Instructions
- (1)IS673 Quick Reference Guide
- (1)A11039 Backlit Console
- (2)A7851 Planter Harness W/Dust Caps (12 Row)
- (1)A8022 Planter Harness W/Dust Caps (6 Row)
- (24)A12650 Seed Tube W/Sensor
- (1)A7858 Radar Sensor
- (2)A12694 Drill Shaft Sensor Mounting Kit
- (2)A8135 Drill Shaft Rotation Sensor Kit
- (1)A8026 Radar Pipe/Mounting Bracket Package
- (1)A7849 Extension Harness W/Female Connectors, 15'
- (4)A8143 50 Pc. Pkg. (D1512) Tie Straps

32 ROW SIZE (Mechanical Seed Metering)
KPM III Monitor Package, 32 Row - 700-05258
(With Magnetic Distance Sensor)
Model 3600TR 16 RN
 (1)IS676 Instructions
 (1)IS673 Quick Reference Guide
 (1)A11039 Backlit Console
 (2)A7852 Planter Harness W/Dust Caps (16 Row)
 (32)A10901 Seed Tube W/Sensor
 (1)A6147 Sensor And Mounting Package
 (1)A7859 MDS Adapter
 (1)A8135 Drill Shaft Rotation Sensor Kit
 (3)A8143 50 Pc. Pkg. (D1512) Tie Straps
 (1)A7853 Junction Y-Harness W/Dust Cap
 (1)A12694 Drill Shaft Sensor Mounting Kit

KPM III Monitor Package, 32 Row - 700-05171
(With Magnetic Distance Sensor)
Model 3800
 (1)IS676 Instructions
 (1)IS673 Quick Reference Guide
 (1)A11039 Backlit Console
 (2)A7852 Planter Harness W/Dust Caps (16 Row)
 (1)A8022 Planter Harness W/Dust Caps (6 Row)
 (32)A10901 Seed Tube W/Sensor
 (1)A6147 Sensor And Mounting Package
 (1)A7859 MDS Adapter
 (2)A12694 Drill Shaft Sensor Mounting Kit
 (2)A8135 Drill Shaft Rotation Sensor Kit
 (1)A7849 Extension Harness W/Female Connectors, 15'
 (5)A8143 50 Pc. Pkg. (D1512) Tie Straps

KPM III Monitor Package, 32 Row - 700-05260
(With Radar Distance Sensor)
Model 3600TR 16 RN
 (1)IS676 Instructions
 (1)IS673 Quick Reference Guide
 (1)A11039 Backlit Console
 (2)A7852 Planter Harness W/Dust Caps (16 Row)
 (32)A10901 Seed Tube W/Sensor
 (1)A7858 Radar Gun
 (1)A8135 Drill Shaft Rotation Sensor Kit
 (1)A8026 Radar Pipe/Mounting Bracket Package
 (3)A8143 50 Pc. Pkg. (D1512) Tie Straps
 (1)A7853 Junction Y-Harness W/Dust Cap
 (1)A12694 Drill Shaft Sensor Mounting Kit

KPM III Monitor Package, 32 Row - 700-05172
(With Radar Distance Sensor)
Model 3800
 (1)IS676 Instructions
 (1)IS673 Quick Reference Guide
 (1)A11039 Backlit Console
 (2)A7852 Planter Harness W/Dust Caps (16 Row)
 (1)A8022 Planter Harness W/Dust Caps (6 Row)
 (32)A10901 Seed Tube W/Sensor
 (1)A7858 Radar Sensor
 (2)A12694 Drill Shaft Sensor Mounting Kit
 (2)A8135 Drill Shaft Rotation Sensor Kit
 (1)A8026 Radar Pipe/Mounting Bracket Package
 (1)A7849 Extension Harness W/Female Connectors, 15'
 (5)A8143 50 Pc. Pkg. (D1512) Tie Straps

32 ROW SIZE (EdgeVac® Seed Metering)
KPM III Monitor Package, 32 Row - 700-05263
(With Magnetic Distance Sensor)
Model 3600TR 16 RN
 (1)IS676 Instructions
 (1)IS673 Quick Reference Guide
 (1)A11039 Backlit Console
 (2)A7852 Planter Harness W/Dust Caps (16 Row)
 (32)A12650 Seed Tube W/Sensor
 (1)A6147 Sensor And Mounting Package
 (1)A7859 MDS Adapter
 (1)A8135 Drill Shaft Rotation Sensor Kit
 (3)A8143 50 Pc. Pkg. (D1512) Tie Straps
 (1)A7853 Junction Y-Harness W/Dust Cap
 (1)A12694 Drill Shaft Sensor Mounting Kit

KPM III Monitor Package, 32 Row - 700-05203
(With Magnetic Distance Sensor)
Model 3800
 (1)IS676 Instructions
 (1)IS673 Quick Reference Guide
 (1)A11039 Backlit Console
 (2)A7852 Planter Harness W/Dust Caps (16 Row)
 (1)A8022 Planter Harness W/Dust Caps (6 Row)
 (32)A12650 Seed Tube W/Sensor
 (1)A6147 Sensor And Mounting Package
 (1)A7859 MDS Adapter
 (2)A12694 Drill Shaft Sensor Mounting Kit
 (2)A8135 Drill Shaft Rotation Sensor Kit
 (1)A7849 Extension Harness W/Female Connectors, 15'
 (5)A8143 50 Pc. Pkg. (D1512) Tie Straps

KPM III Monitor Package, 32 Row - 700-05265
(With Radar Distance Sensor)
Model 3600TR 16 RN
 (1)IS676 Instructions
 (1)IS673 Quick Reference Guide
 (1)A11039 Backlit Console
 (2)A7852 Planter Harness W/Dust Caps (16 Row)
 (32)A12650 Seed Tube W/Sensor
 (1)A7858 Radar Gun
 (1)A8135 Drill Shaft Rotation Sensor Kit
 (1)A8026 Radar Pipe/Mounting Bracket Package
 (3)A8143 50 Pc. Pkg. (D1512) Tie Straps
 (1)A7853 Junction Y-Harness W/Dust Cap
 (1)A12694 Drill Shaft Sensor Mounting Kit

KPM III Monitor Package, 32 Row - 700-05204
(With Radar Distance Sensor)
Model 3800
 (1)IS676 Instructions
 (1)IS673 Quick Reference Guide
 (1)A11039 Backlit Console
 (2)A7852 Planter Harness W/Dust Caps (16 Row)
 (1)A8022 Planter Harness W/Dust Caps (6 Row)
 (32)A12650 Seed Tube W/Sensor
 (1)A7858 Radar Sensor
 (2)A12694 Drill Shaft Sensor Mounting Kit
 (2)A8135 Drill Shaft Rotation Sensor Kit
 (1)A8026 Radar Pipe/Mounting Bracket Package
 (1)A7849 Extension Harness W/Female Connectors, 15'
 (5)A8143 50 Pc. Pkg. (D1512) Tie Straps

36 ROW SIZES (Mechanical Seed Metering)

KPM III Monitor Package, 36 Row - 700-05173 (With Magnetic Distance Sensor)

Model 3700

- (1)IS676 Instructions
- (1)IS673 Quick Reference Guide
- (1)A11039 Backlit Console
- (2)A8050 Planter Harness W/Dust Caps (18 Row)
- (36)A10901 Seed Tube W/Sensor
- (1)A6147 Sensor And Mounting Package
- (1)A7859 MDS Adapter
- (1)A12694 Drill Shaft Sensor Mounting Kit
- (1)A8135 Drill Shaft Rotation Sensor Kit
- (4)A8143 50 Pc. Pkg. (D1512) Tie Straps

KPM III Monitor Package, 36 Row - 700-05175 (With Magnetic Distance Sensor)

Model 3800

- (1)IS676 Instructions
- (1)IS673 Quick Reference Guide
- (1)A11039 Backlit Console
- (2)A7852 Planter Harness W/Dust Caps (16 Row)
- (1)A8022 Planter Harness W/Dust Caps (6 Row)
- (36)A10901 Seed Tube W/Sensor
- (1)A6147 Sensor And Mounting Package
- (1)A7859 MDS Adapter
- (2)A12694 Drill Shaft Sensor Mounting Kit
- (2)A8135 Drill Shaft Rotation Sensor Kit
- (1)A7849 Extension Harness W/Female Connectors, 15'
- (5)A8143 50 Pc. Pkg. (D1512) Tie Straps

KPM III Monitor Package, 36 Row - 700-05174 (With Radar Distance Sensor)

Model 3700

- (1)IS676 Instructions
- (1)IS673 Quick Reference Guide
- (1)A11039 Backlit Console
- (2)A8050 Planter Harness W/Dust Caps (18 Row)
- (36)A10901 Seed Tube W/Sensor
- (1)A7858 Radar Sensor
- (1)A12694 Drill Shaft Sensor Mounting Kit
- (1)A8135 Drill Shaft Rotation Sensor Kit
- (1)A8026 Radar Pipe/Mounting Bracket Package
- (4)A8143 50 Pc. Pkg. (D1512) Tie Straps

KPM III Monitor Package, 36 Row - 700-05176 (With Radar Distance Sensor)

Model 3800

- (1)IS676 Instructions
- (1)IS673 Quick Reference Guide
- (1)A11039 Backlit Console
- (2)A7852 Planter Harness W/Dust Caps (16 Row)
- (1)A8022 Planter Harness W/Dust Caps (6 Row)
- (36)A10901 Seed Tube W/Sensor
- (1)A7858 Radar Sensor
- (2)A12694 Drill Shaft Sensor Mounting Kit
- (2)A8135 Drill Shaft Rotation Sensor Kit
- (1)A8026 Radar Pipe/Mounting Bracket Package
- (1)A7849 Extension Harness W/Female Connectors, 15'
- (5)A8143 50 Pc. Pkg. (D1512) Tie Straps

36 ROW SIZES (EdgeVac® Seed Metering)

KPM III Monitor Package, 36 Row - 700-05205 (With Magnetic Distance Sensor)

Model 3700

- (1)IS676 Instructions
- (1)IS673 Quick Reference Guide
- (1)A11039 Backlit Console
- (2)A8050 Planter Harness W/Dust Caps (18 Row)
- (36)A12650 Seed Tube W/Sensor
- (1)A6147 Sensor And Mounting Package
- (1)A7859 MDS Adapter
- (1)A12694 Drill Shaft Sensor Mounting Kit
- (1)A8135 Drill Shaft Rotation Sensor Kit
- (4)A8143 50 Pc. Pkg. (D1512) Tie Straps

KPM III Monitor Package, 36 Row - 700-05207 (With Magnetic Distance Sensor)

Model 3800

- (1)IS676 Instructions
- (1)IS673 Quick Reference Guide
- (1)A11039 Backlit Console
- (2)A7852 Planter Harness W/Dust Caps (16 Row)
- (1)A8022 Planter Harness W/Dust Caps (6 Row)
- (36)A12650 Seed Tube W/Sensor
- (1)A6147 Sensor And Mounting Package
- (1)A7859 MDS Adapter
- (2)A12694 Drill Shaft Sensor Mounting Kit
- (2)A8135 Drill Shaft Rotation Sensor Kit
- (1)A7849 Extension Harness W/Female Connectors, 15'
- (5)A8143 50 Pc. Pkg. (D1512) Tie Straps

KPM III Monitor Package, 36 Row - 700-05206 (With Radar Distance Sensor)

Model 3700

- (1)IS676 Instructions
- (1)IS673 Quick Reference Guide
- (1)A11039 Backlit Console
- (2)A8050 Planter Harness W/Dust Caps (18 Row)
- (36)A12650 Seed Tube W/Sensor
- (1)A7858 Radar Sensor
- (1)A12694 Drill Shaft Sensor Mounting Kit
- (1)A8135 Drill Shaft Rotation Sensor Kit
- (1)A8026 Radar Pipe/Mounting Bracket Package
- (4)A8143 50 Pc. Pkg. (D1512) Tie Straps

KPM III Monitor Package, 36 Row - 700-05208 (With Radar Distance Sensor)

Model 3800

- (1)IS676 Instructions
- (1)IS673 Quick Reference Guide
- (1)A11039 Backlit Console
- (2)A7852 Planter Harness W/Dust Caps (16 Row)
- (1)A8022 Planter Harness W/Dust Caps (6 Row)
- (36)A12650 Seed Tube W/Sensor
- (1)A7858 Radar Sensor
- (2)A12694 Drill Shaft Sensor Mounting Kit
- (2)A8135 Drill Shaft Rotation Sensor Kit
- (1)A8026 Radar Pipe/Mounting Bracket Package
- (1)A7849 Extension Harness W/Female Connectors, 15'
- (5)A8143 50 Pc. Pkg. (D1512) Tie Straps

INTERPLANT® MONITOR PACKAGES

(Mechanical Seed Metering)

Interplant® Monitor Package,

4 Row - 700-05114

Model 3000

- (1)A8021 Planter Harness W/Dust Caps (4 Row)
- (3)A10901 Seed Tube W/Sensor
- (1)A7853 Junction Y-Harness W/Dust Cap
- (1)A8143 50 Pc. Pkg. (D1512) Tie Straps

Interplant® Monitor Package,

6 Row - 700-05115

Models 3000 And 3500

- (1)A8021 Planter Harness W/Dust Caps (4 Row)
- (5)A10901 Seed Tube W/Sensor
- (1)A7853 Junction Y-Harness W/Dust Cap
- (2)A8143 50 Pc. Pkg. (D1512) Tie Straps

Interplant® Monitor Package,

8 Row - 700-05116

Models 3000, 3500 And 3600

- (1)A8022 Planter Harness W/Dust Caps (6 Row)
- (7)A10901 Seed Tube W/Sensor
- (1)A7853 Junction Y-Harness W/Dust Cap
- (2)A8143 50 Pc. Pkg. (D1512) Tie Straps

Interplant® Monitor Package,

12 Row - 700-05117

Models 3400, 3600 And 3650

- (1)A7851 Planter Harness W/Dust Caps (12 Row)
- (11)A10901 Seed Tube W/Sensor
- (1)A7853 Junction Y-Harness W/Dust Cap
- (2)A8143 50 Pc. Pkg. (D1512) Tie Straps

Interplant® Monitor Package,

16 Row - 700-05118

Models 3600 And 3650

- (15)A10901 Seed Tube W/Sensor
- (1)A7853 Junction Y-Harness W/Dust Cap
- (1)A7852 Planter Harness W/Dust Caps (16 Row)
- (3)A8143 50 Pc. Pkg. (D1512) Tie Straps

INTERPLANT® MONITOR PACKAGES

(EdgeVac® Seed Metering)

Interplant® Monitor Package,

4 Row - 700-05252

Model 3000

- (1)A8021 Planter Harness W/Dust Caps (4 Row)
- (3)A12650 Seed Tube W/Sensor
- (1)A7853 Junction Y-Harness W/Dust Cap
- (1)A8143 50 Pc. Pkg. (D1512) Tie Straps

Interplant® Monitor Package,

6 Row - 700-05253

Models 3000 And 3500

- (1)A8021 Planter Harness W/Dust Caps (4 Row)
- (5)A12650 Seed Tube W/Sensor
- (1)A7853 Junction Y-Harness W/Dust Cap
- (2)A8143 50 Pc. Pkg. (D1512) Tie Straps

Interplant® Monitor Package,

8 Row - 700-05254

Models 3000, 3500 And 3600

- (1)A8022 Planter Harness W/Dust Caps (6 Row)
- (7)A12650 Seed Tube W/Sensor
- (1)A7853 Junction Y-Harness W/Dust Cap
- (2)A8143 50 Pc. Pkg. (D1512) Tie Straps

Interplant® Monitor Package,

12 Row - 700-05255

Models 3400, 3600 And 3650

- (1)A7851 Planter Harness W/Dust Caps (12 Row)
- (11)A12650 Seed Tube W/Sensor
- (1)A7853 Junction Y-Harness W/Dust Cap
- (2)A8143 50 Pc. Pkg. (D1512) Tie Straps

Interplant® Monitor Package,

16 Row - 700-05256

Models 3600 And 3650

- (15)A12650 Seed Tube W/Sensor
- (1)A7853 Junction Y-Harness W/Dust Cap
- (1)A7852 Planter Harness W/Dust Caps (16 Row)
- (3)A8143 50 Pc. Pkg. (D1512) Tie Straps

KINZE®, the *KINZE®* logo, *Econo-Fold®*, *Twin-Line®*, *Interplant®* and *EdgeVac®* are registered trademarks of *KINZE Manufacturing, Inc.*